

Operating Manual

all4-PCB (Switzerland) Ltd.
Kuster Engineering Division

Ringstrasse 39
CH- 4106 Therwil
Phone +41 61 726 95 11
Fax +41 61 726 95 28

info@all4-PCB.com
www.all4-PCB.com

Spraycoater KU451
Machine No. 07.2450.10

Pumping station KU550
Machine No. 07.2451.08



Customer:

Table of contents

Introduction	3
Set-up Requirements.....	4
Warranty terms.....	5
General safety notes.....	6
Intended operation rules.....	10
Technical data.....	11
Spraycoater KU451	12
Description of machine.....	13
Spray cabin.	13
Air extraction system.....	16
Heaters.....	19
Transport system.....	20
Width adjustment system.....	22
Spray head.....	24
Lacquer recycling.....	27
Control system.....	31
Operating the touch-screen	32
Start up picture.....	33
Alarm messages.....	34
Set panel size.....	35
Parameter setting.....	36
Data management.....	38
System.....	40
Pneumatic control system.....	43
Adjustment wet weight.....	44
Pumping station KU550	45
Function	45
Piping	46
Lacquer circulation.....	47
Viscosimeter	48
Operating the touch-screen	49
Setting lacquer pressure.....	49
Parameter setting.....	51
Cleaning procedure.....	52

Maintenance

Equipment for the application of liquid soldermasks by spray coating.

With an automatic loading device or by hand, the panels are deposited on the transport system with as short a gap as possible between each other. They are automatically passing under the spray head. A switch at the entrance of the machine activates a valve in the spray head and gives way for the lacquer flow and the oscillation of the spray head itself.

To assure a constant coating surface of the panels it's important to place a dummy in front of the first and another dummy after the last panel. The first dummy switches on the transport system and herewith, the spraying process is activated and starts time-delayed running.

The lateral overspray is collected by a patented collecting system with a collecting belt and a squeegee. The recovered lacquer can manually be brought back to the lacquer circulation system so that the loss of material will be reduced to a minimum.

Purpose of this manual

This manual is designed to provide buyers and users with all the information they will need to handle, install, operate, clean and service their spray coating machine correctly. Like the preliminary operator training provided by All4-PCB (Switzerland) Ltd. personnel etc., this manual will help you to use the spray coating machine as intended and ensure its constant availability.

To draw the full benefit from the machine's capabilities it is essential for you to pay strict attention to the instructions in this manual.



Machine may only be used by trained or instructed personnel

Speaking on our own behalf

In the interest of our customers we reserve modifications due to technical progress. Illustrations, descriptions and delivery volume are therefore not binding.

Kein Teil dieser Veröffentlichung darf ohne schriftliche Genehmigung der All4-PCB (Switzerland) Ltd. in jeglicher Weise reproduziert, gesendet, übertragen, in einem Datenverarbeitungssystem gespeichert, oder in eine andere Sprache übersetzt werden.

Without the written permission of All4-PCB (Switzerland) Ltd. no part of this document may neither be copied, transmitted, nor be stored in a data processing system or translated into another language.

Copyright by All4-PCB (Switzerland) Ltd. All rights reserved.

Customer-specific requirements

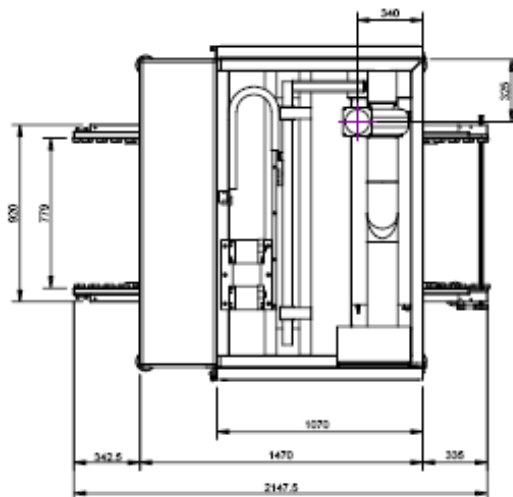
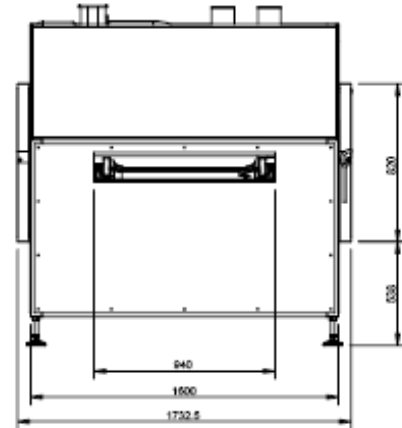
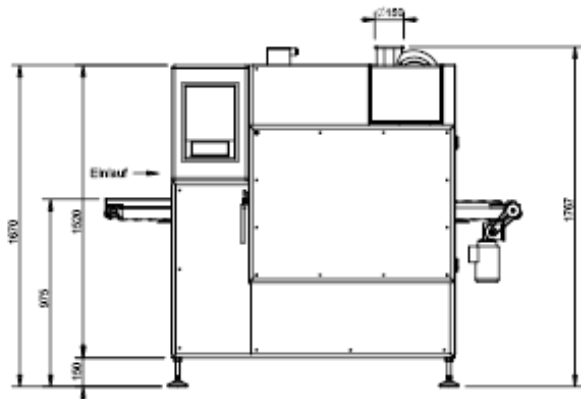

Transport width: 300-760mm
 Panel length: 300-1500mm
 Panel weight: max. 10kg/PCB
 Panel thickness: 1-10mm, depending on width
 Laquer-free edge: 0-10mm adjustable
 Max. twist: max. 1% (diagonal)
 Parallelism of panel: 0.5mm, rounded Edges
 Speed of transport system: max. 1,8m/min,
 optional 2,4m/min
 Ink supply: pressure pot with manometer (optional
 pump unit)
Infrastructure data
 Elektrical conection: 400V, 3Ph, 50Hz (opt. 480V,
 3Ph, 60Hz)
 Installed power: 12kW
 Exhaust volume: 600m³/h
 Compressed air: 6 bar, 500l/min (dry & oilfree)
 Feeding on site centrally

Room

Solvents and solventcontaining vapours are used within the workroom. Therefore, no ignition sources may be within the room.

Roomtemperature: 22 ± 2°C
 Relative humidity: 45-60%
 Air quality: Class 100'000
 Air regeneration: 10 x per hour
 Atmospheric pressure: + 3mm WC

Floor

Quality: Antistatic, synthetic stone or preferably araldite
 Load-carrying capacity: min. 2'000 kg/m²
 Vibration-free surrounding

Lighting

Yellow light fluorescent tubes
 e.g. Philips Type TLD 36W/16
 Daylight filters at the windows
 e.g. plexiglass GS, yellow 303 (Röhm + Haas)

Transport, Installation and Start-up

Transport

The shipment is executed according to the wishes and instructions of the buyer.

If the machinery is not installed immediately, it should always be kept in the closed packaging and stored in dry rooms!

Installation, Connection and Start-up

The machinery will be installed, connected up (air system, pneumatics, electrics) by the customer under advise and supervision of the all4-PCB installation engineer. Start-up for the first time (including all settings) by the all4-PCB Installation engineer in the customer's presence and with his help, as this forms part of the instruction provided for the customer's personnel.

Please use a fork lift to lift, transport and place the machine and be carefull to avoid any damaging of parts of the equipment.

Warranty terms

Assert warranty claims in writing.

At the customer's written request we undertake to repair or replace at our discretion and as quickly as possible all parts that become faulty or useless as the demonstrable result of poor materials, faulty design or defective execution. Replaced parts become our property!

We shall bear the costs of any faulty parts requiring replacement, but not the costs of transport to us and back to the customer, nor the costs of packing and insurance!

Warranty:

On all delivered products all4-PCB shall provide a 12 month warranty starting from the day of the final acceptance by the customer (acceptance report).

We shall not be liable for any damage resulting from normal wear and tear, improper handling, deficient maintenance, non-observance of the operating instructions, excessive loading and any other reasons for which we are not responsible!

We shall also refuse to accept any liability if the customer carries out repairs or changes to the machine himself - or has others carry them out - without our written consent!

The warranty does not cover damage in transit, drive belts, batteries, bulbs, fuses and any readjustments in accordance with the Operating Manual!

General safety notes



Please read now and avoid damage and injury later

The equipment is built in accordance with today's state of engineering and is safe to operate. Special attention has been given to user safety and to the ergonomic arrangement of controls.



Declaration of conformity

The machine conforms with the standards and safety regulations (DIN, IEC, VGB 24) in force at the time of delivery.

Each machine is subjected to thorough testing prior to shipment.

It is imperative for every person who is involved with the installation, start-up, operation and maintenance (inspection, servicing, repair) of the machine at the user's factory, to have read and understood the complete Operating Manual, particularly the chapter on "Safety".

Lay down responsibilities

Responsibilities for the installation, operation and maintenance of the machine must be clearly defined and observed in order to rule out all uncertainty with regards to safety. The user shall be co-responsible for ensuring that no unauthorized personnel work on the machine.

This means that only authorized, trained and instructed personnel shall be allowed to operate, service and repair the machine. Personnel must be warned of the risks by their superiors.



Ensure safe mode of operation

Avoid all mode of operation which could affect the security of the machine.

The operating personnel is bound to immediately inform the supervisor in case of changes related to the security of the machine

The user is bound to always operate the machine in a perfect condition.

Through corresponding instructions and inspections the user has to make sure that the cleanliness and clearness of the working place is warranted.

Arbitrary rebuilds and modifications which could influence the security are not allowed.

Pay attention to the switch-off procedure

For all interventions regarding installation, start-up, operation, rearrangement, adabtation and maintenance the switch-off procedure mentioned in the operation manual have to be strictly respected.

Built-in security devices

In any cases it is not allowed to bridgeover the the built-in devices. This affects mainly all switches outside the machine which are easy accessible like main switch, security switch, emergency switch and sensors.

It's only permitted to operate the machine if the neutral wire and grounding conductor are properly connected.

Manipulations in the control cabinet are exclusively allowed for qualified personnel. Use only original spare parts!

Midifications on the software are only allowed with the agreement of all4-PCB ore all4-PCB it self.



Accomplish maintenance and repairing works after having shut down the machine!

All maintenance and repairing works have to be done at machine shutdown. Before starting this kind of works, switch off the main switch and assure it agains unintentional switch on. Before switching on the machine after this works have been finished, make sure that all protection parts are mounted again.

Observe local regulations

For the operation of the equipment, the local regulations regarding security and accident prevention have in any case to be respected!

Personally protection



It's only allowed to operate the machine if a accordingly connected and activated ventilation has been insalled.

When working with lacquers



In any case, wear protective goggles when processing



In any case, wear solvent-resistant gloves.



When handling solvents, e.g. during cleaning, etc.:
A suitable breathing mask must be worn.



If any substance gets splashed into your eyes accidentally, wash out immediatly with flowing water for 10 to 15 minutes. Then visit the doctor at all cost.



Splashes on your skin:

- Dab off (do not rub)
- Wash and apply cleansing cream.

In the event of severe inflammation of the skin and in cases of doubt, visit the doctor at all cost.

Safety rules for lacquers



Never use synthetic rags to clean the machine. Old rags must be discarded in the lock-up waste bin provided.

The machine must be used in such a way as to avoid excessive heating of any of its parts.

Unused solvent containers must always be closed.



Smoking, eating and drinking are prohibited in all rooms where lacquers are used!



Only the smallest possible quantities of inflammable chemicals - never more than 10 litres - may be stored in the machine room. Their containers must always be kept a distance of at least 5 metres away from electric equipment. Local regulations concerning such arrangements shall always apply. Like other UV-sensitive materials, ®PROBIMER lacquers must be protected from light and heat.

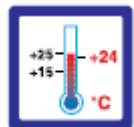

Store in the temperature range from 15°C to 25°C.

Lacquer must be mixed at a suitable place that is specially provided for the purpose (ventilation in conformance with the regulations, explosion protection of electrical equipment in accordance with VDE or similar).



Install fire extinguisher

Depending on its size the machine room must be equipped with at least 1 easy-to-reach and ready-to-use fire extinguisher, which is best positioned close to the entrance door.

Additional fire extinguishers can be positioned in the corners furthest away from the entrance door.

Agents suitable for fighting solvent fires are, for example, foam (stabilized), carbon dioxide and halon. Fire classification A, B, C.

Size IV is adequate for 50 to 100 m².



Danger areas



Safety devices and safety circuits:
- do not remove and
- do not render them ineffective!

A ventilation system must be installed.
Ventilation of installation site must be guaranteed.

In any case, switch off main switch before opening control cabinet.
However, main switch doesn't separate machine from compressed air system.



Danger of injury during running of machine:
- Do not open doors!
- Do not grasp into running transport devices



Don't leave the operational areas while processing



Danger of burning
→ Don't touch the heating



Don't open the door while processing



In case of an emergency stop process by pushing the emergency-stop switch

In emergency case switch off the equipment with the emergency-stop switch

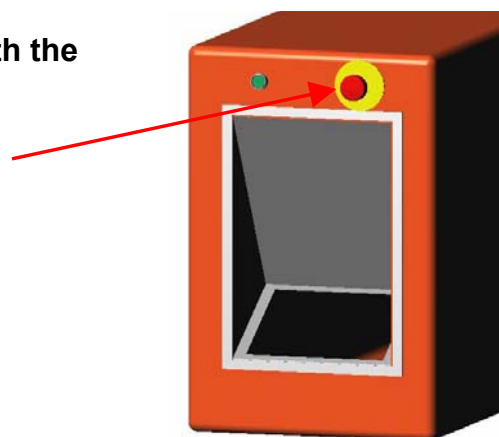

Intended Operation Rules

Intended Operation Rules of the machine

This machine may be dangerous if not being handled by instructed staff. It can also be dangerous when handled in an inappropriate manner or for a wrong use.

Part of the intended operation rules are also the installation, operating and maintenance conditions prescribed by the manufacturer.

The equipment has exclusively been designed for coating and drying of printed circuit boards.

All deviant use are considered as not corresponding to the intended operation rules. In that case the manufacturer declines all responsibility for possible damages; the user bears the risk alone.

Misusage

As not corresponding to the intended operation rules and declining all liability of the manufacturer are considered:

Non-intended use (manufacturer not be liable for damage resulting from such use):

- Any other or additional use in contravention of the intended use specified above.
- Non-compliance of safety instructions.
- If malfunctions affecting safety are not removed before starting production.
- Manipulations on machine systems affecting correct function, unrestricted use and active/passive safety.
- Unauthorized modifications and changes to the machine which might affect safety.
- If the machine is not in a perfect condition and if it is operated not safety/danger-conscious and without observing all directions given in the Operating Instructions, e.g.:
 - Operating the machine without earthing.
 - Using EMERGENCY STOP push-buttons as Off switches.
 - Installing non-professional cable connections.

Connection Values / Technical Data

Spray-Coater

Current supply	3x400V / 50Hz / max. 32A
Compressed air	6 bar / approx. 600l/min
Total Exhaust Air	approx. 500 m ³ /h
Exhaus Ventilator Intenal Space	Elektor D064 1 kW / 3x400V / 50Hz
Drive Oszillation Sprayhead	Servomotor 400 W R7M-A40030-S1, OMRON With linear unit
Drive Transport System	Ex-Motor 180 W EAFY63/4B-7, Flender Worm Gear i=40 MVF 30, Bonfiglioli
Drive Lacquer Collecting Belts	Ex-Motor , 120W B63A4B3 Bonfiglioli Step-down Gear 1:6
Drive Width Adjustment	Ex-Motor , 120W B63A4B3 Bonfiglioli Step-down Gear 1:50
Drive Lacquer Pump	3x230VAC/370W Step-down Gear 1:10
Sprayair Temperature Monitoring	PT 100 7138-1-PT-P-10, EHS
Temperature Control Unit	Software Controller with PID behavior
Security Thermostate	mech. Switch EM-5/N2, JUMO
Excess Temperature Security	Temperature Probe PT 100 7138-1-PT-P-10, EHS
Heating	Spray Air 2kW Horn Air 2kW all4-PCB

Spraycoater KU451

Quality characteristics:

- Modular design with observance of pertinent standards.
- Full integration capability in upstream or downstream processing cycles, depending on the level of automation
- Dimensioned for continuous operation (multiple shift)
- High productivity and low labour requirement
- On the process and control engineering side, all modules of the spraycoater are interlinked via a freely programmable control system through the main switchgear and control cabinet
- User-friendly control console for simple operation
- Integrated MODEM for diagnostic purposes via service center (optional)
- Lacquer saving by lacquer recycling
- Less pollution by the sealed cabin

The spraycoater is made up of the following components:

1. Spray cabin
2. Air extraction system
3. Air heater
4. Transportsystem
5. Width adjustment system
6. Sprayhead
7. Lacquer recycling
8. Control system Touchscreen
9. Pneumatic control system

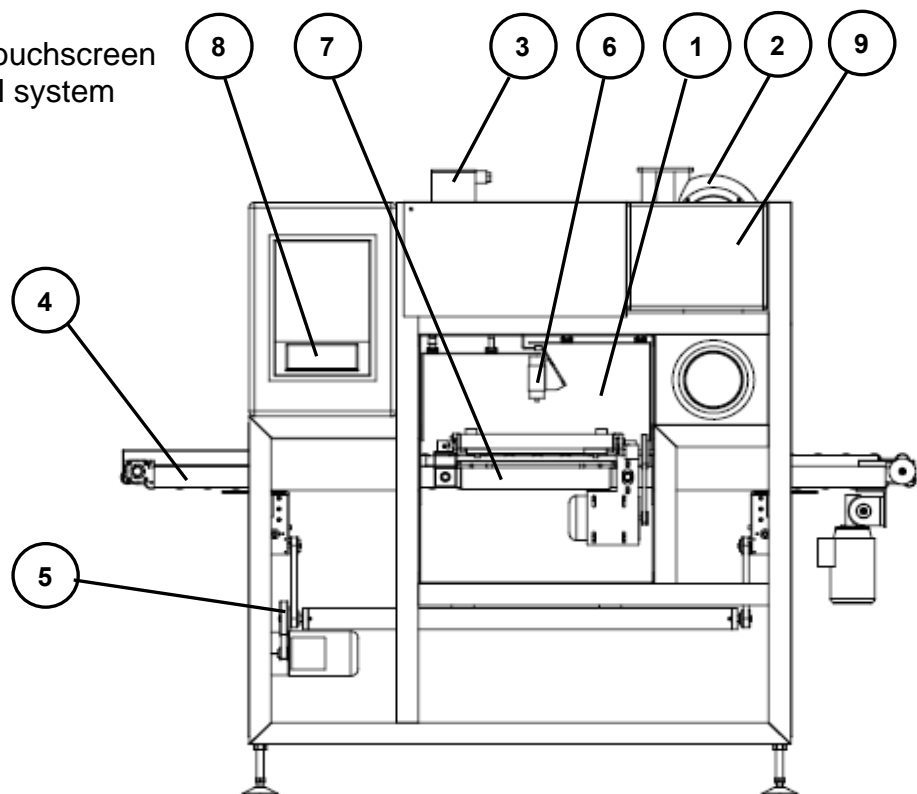

1. Spray cabin

The spray cabin is tightly built of stainless sheet metal. Two massive doors cover the cabin on both sides. A rubber gasket on each of these doors will be pressed to the frame when the doors are closed. At the same time the two rubber plugs get pushed to the filter handles for tightening the filter housing to the air extraction system.

The inner side of the cabin has a smooth surface for a better cleaning. Additionally there are two angular sheets fit to the top of spray cabin. These sheets can either be changed, or cleaned outside of the machine.

There is a door limit switch on each door to control that the doors are closed while processing. Once a door is opened while the automatic process is still running, the machine stops immediately, like an emergency stop.

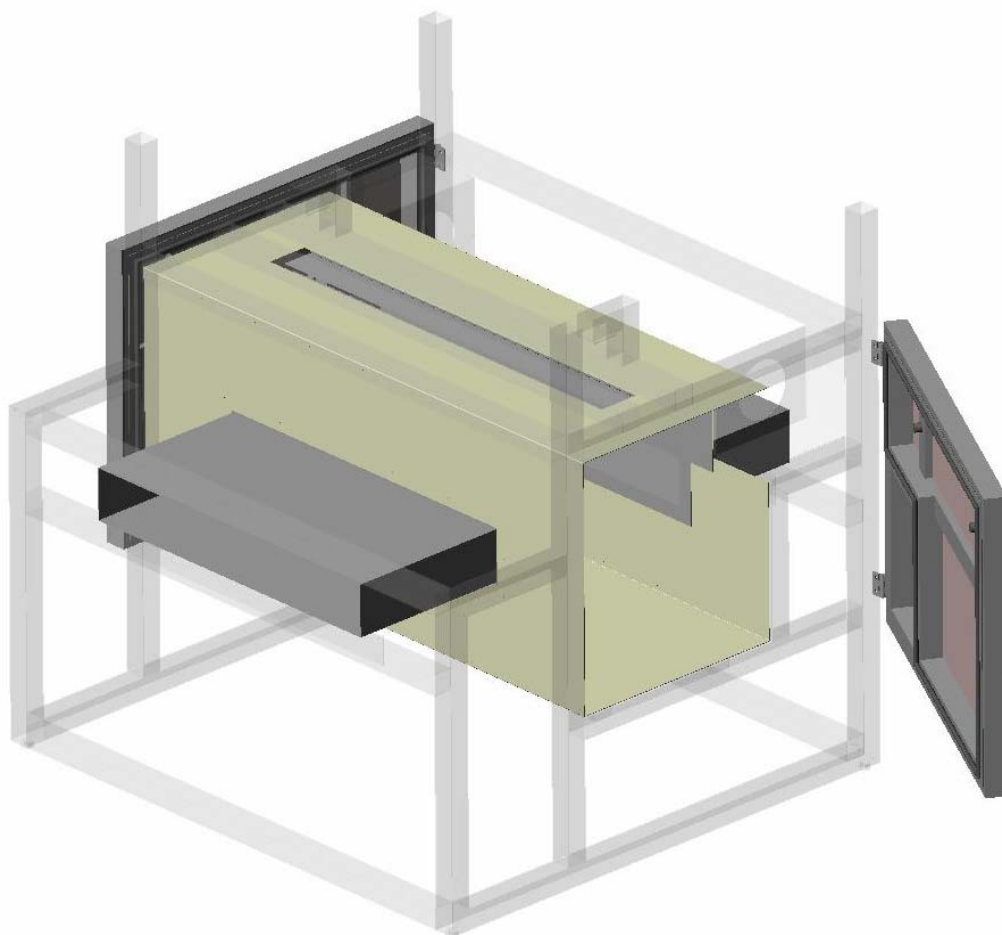

Doors

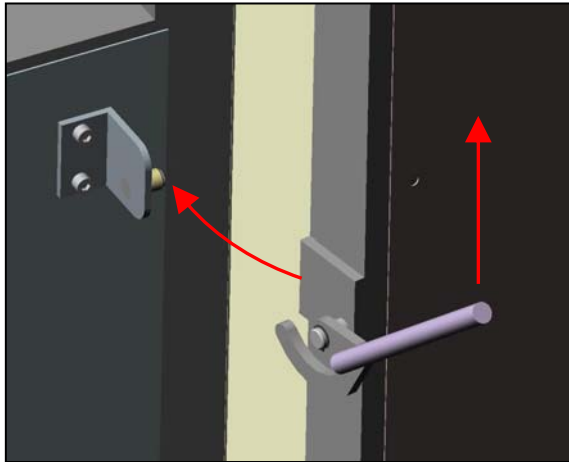

To lock the door lift up the handle and hook it into the bolt.

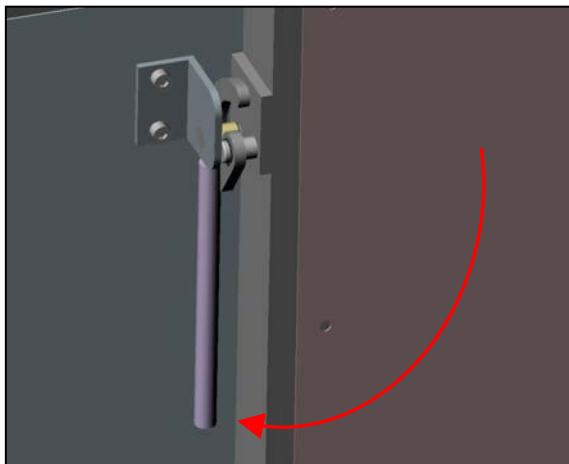

Don't slam the door. The handle must be lifted up before locking the door.

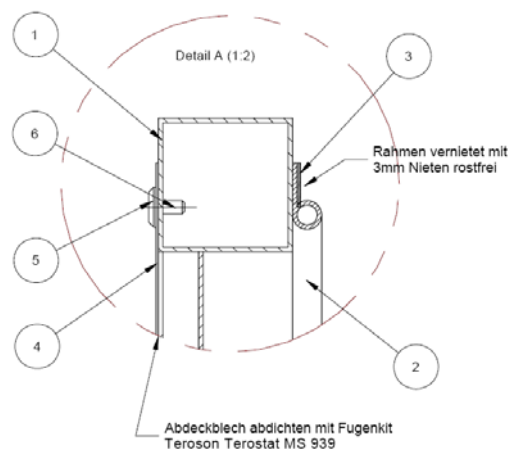
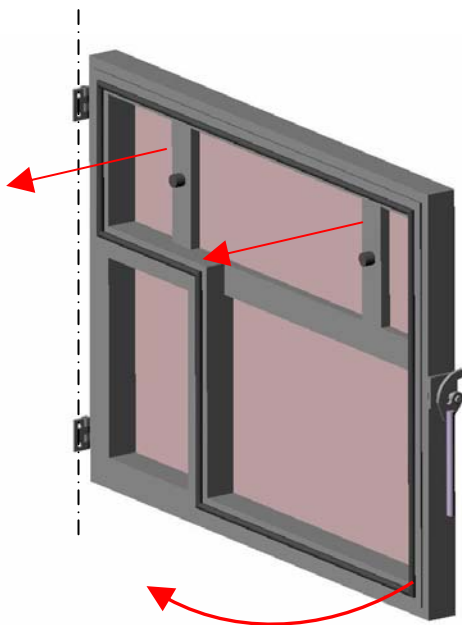

Cleaning the spray cabin

Die Spraykabine und der Spraykopf sind täglich, bei Arbeitsende zu reinigen. Die Kabinenbleche sind dazu bequem zu entfernen.

Vorgehen:

1. Open the doors and remove the filters
2. Remove the collecting belts and the collecting tray
3. Remove the angular sheets
4. Remove the chain protecting sheets
5. Replace the paper
6. Remove the sprayhead
7. Clean the cabin
8. Clean all the components to be reassembled

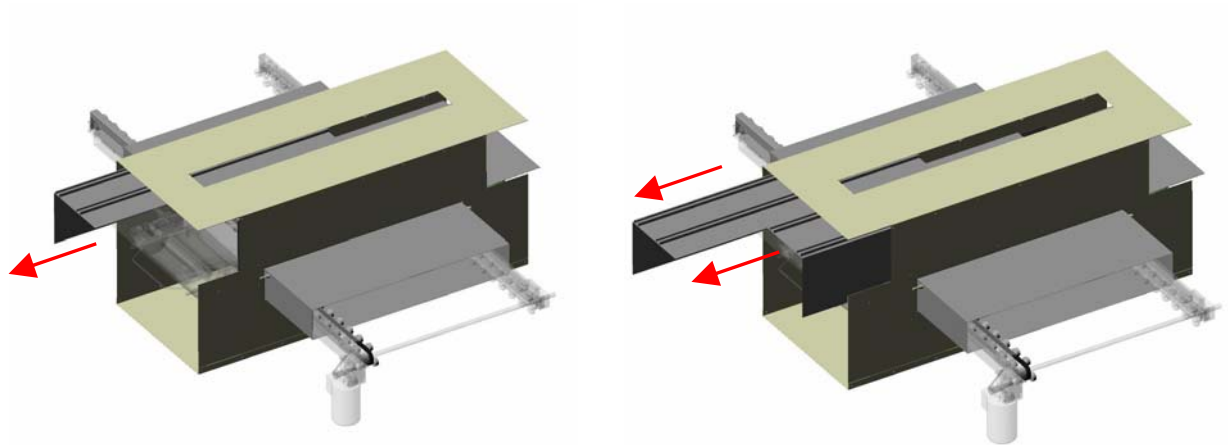

Remove the angular sheets

cabin sheets

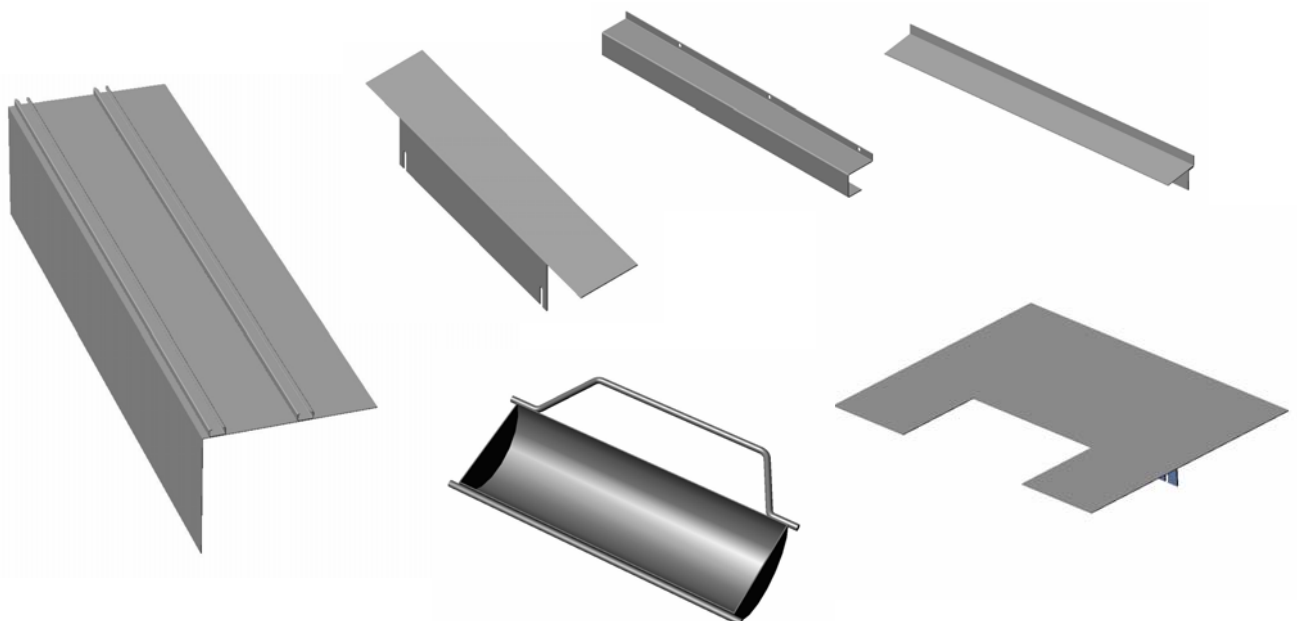

2. Air extraction system

Extraction concept

The spray cabin is built up tight with three inlet openings (opening sprayhead, machine inlet and outlet). In the cabin is a vacuum caused by the ventilator. Therefore the solvent vapor is extracted and filtered in the filter cases. The filter cases are placed on both sides of the cabin and fixed by locking the doors.

A support on the roof of the cabin carries the filter housing and beware of installing the wrong way.

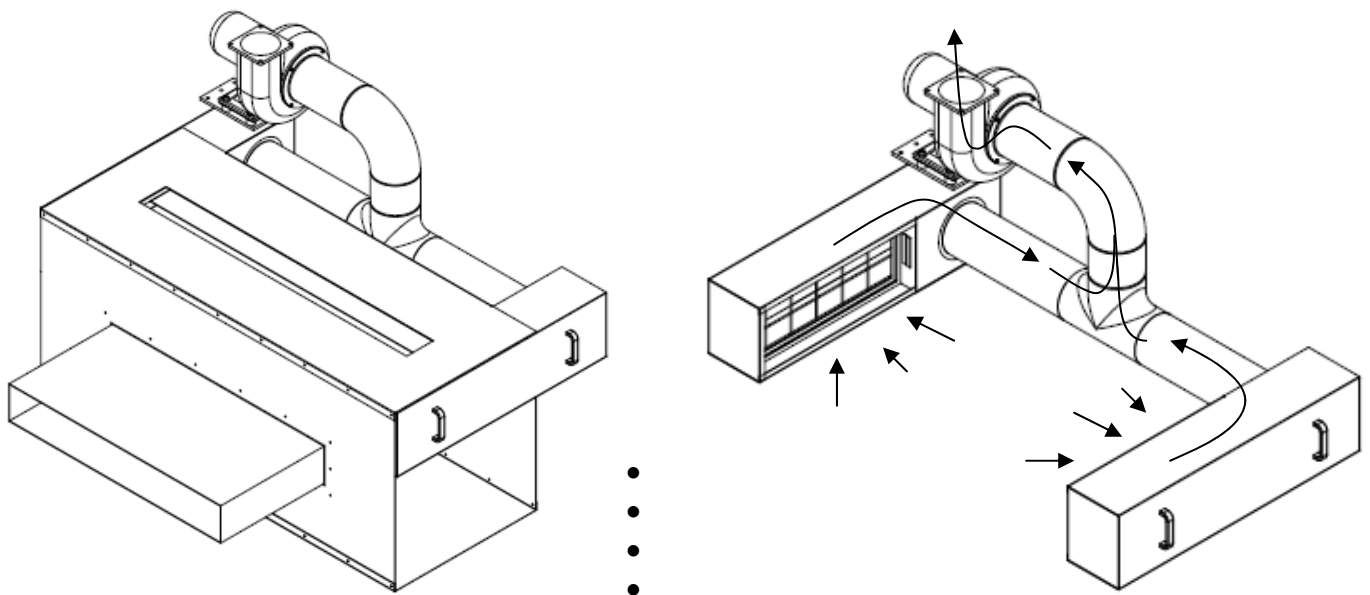

The inner side of the spray cabin is declared as a explosion-proof zone. The extraction system must be in function while processing.

Extracion monitoring

The operability of the air extraction system is essential for an automatic process. Therefore the system is controlled by a differential air pressure detecting system.

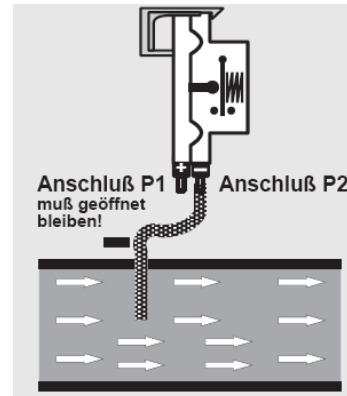

Solvent with a flashpoint below 21°C must not be used on this machine



It's not allowed to spray solvent

Air knives

In order to avoid that contaminated air is escaping into the environment, they are an air knife at the inlet and at the outlet of the machine. The air pressure has to be adjusted so that no lacquer moisture can leave the machine. Neither at the inlet nor at the outlet. The pressure gauge is placed in the pneumatic control box on top of the machine. (see pneumatic control)

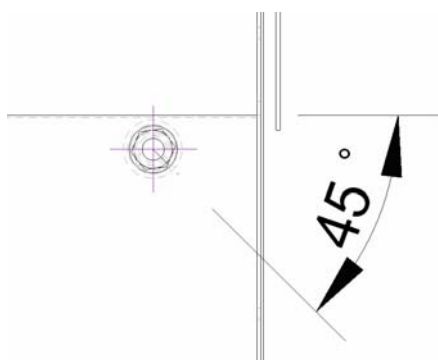
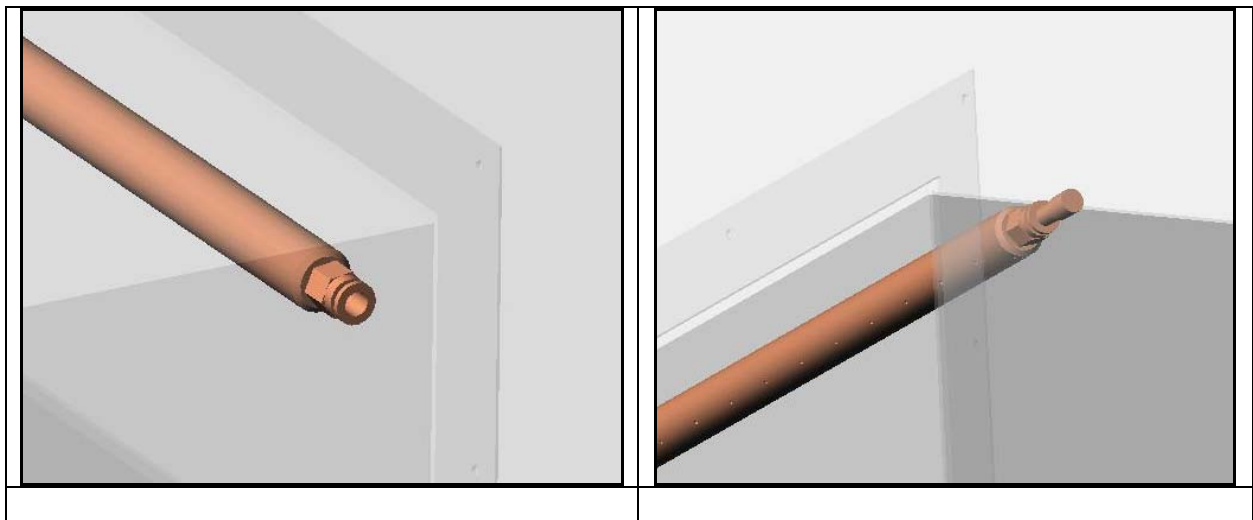
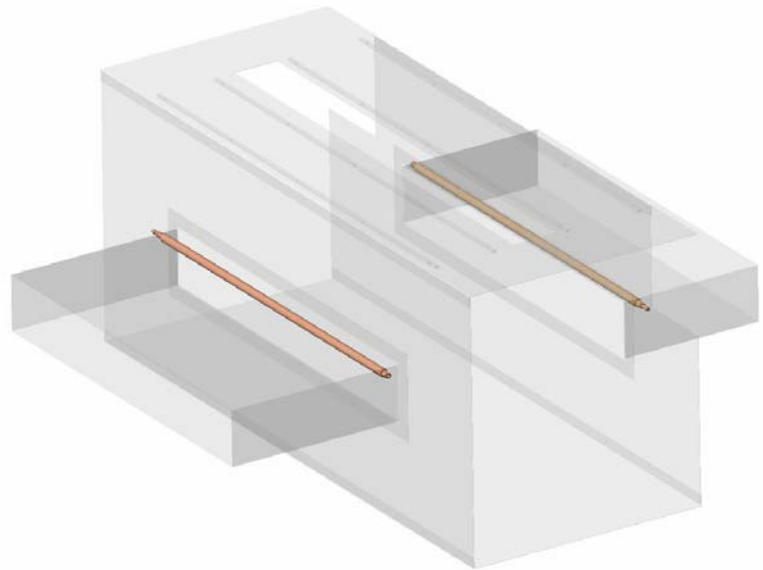

Basic setting of the air knives 45°

Air pressure about 0.5 bar

3. Heaters

Two heating elements of 1kW capacity each are heating the spraying air and the horn air.

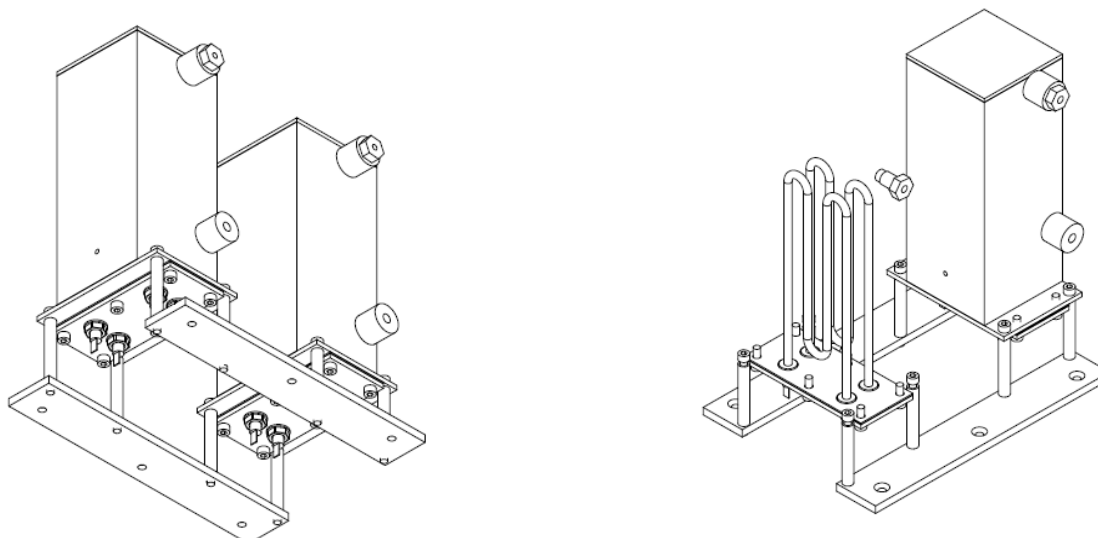

Heater of the spraying air with temperature probe, excess temperature control and safety thermostats

Temperature probe

2 Temperature probes PT 100 are placed in air heaters, controlling the temperature of the spray air and the horn air. The actual temperatures can be read off on the touchscreen. The temperature developing can be observed on the touchscreen under „curves“

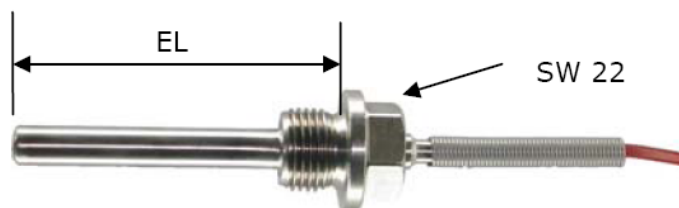

Safety thermostats

The safety thermostat consists in a temperature probe and a mechanical switch. The probe is placed close to the heating element and the mechanical switch is sitting near by the heater housing on top of the machine.

The maximum trigger temperature can be set with a screwdriver by rotating the disk. The maximum allowed trigger temperature should not be set higher than 200°C.

The activation of the safety thermostate causes an immediate switch off of the heating elements and a corresponding alarm appears on the touchscreen. A possible breakdown of a PC 100 is checked by the PLC.



4. Transport System

The panels are transported through the machine on plastic supports fixed on the transport chain. This supports are only plugged to the chain and they can easily and without tool be removed for cleaning

The tension device to span the chain is placed on the inlet side of the machine.

The driving motor for the transport chain is placed on outlet side of the machine, outside the casing.

The transport speed is electronically set by the control system on the touchscreen

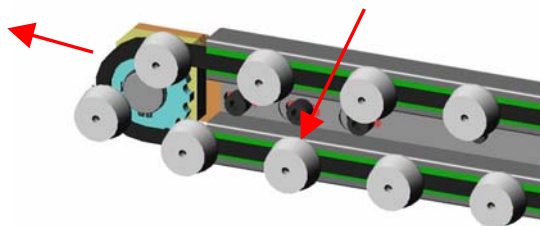

Tension device to span the chain

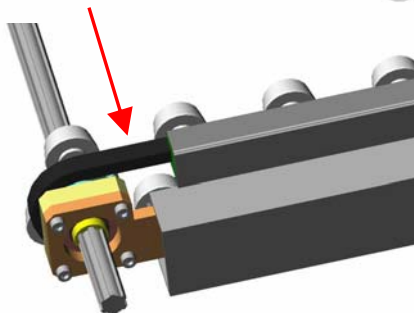

On the outlet side are gaps to enable the opening of the master links

Chain Drive

On the outlet side is the drive motor for the transport chain.
The transport speed is electronically set by the control system on the touchscreen.

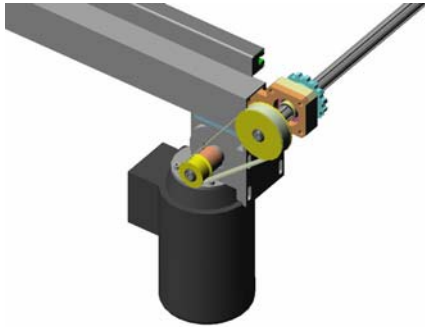

Drive motor of the transport chain

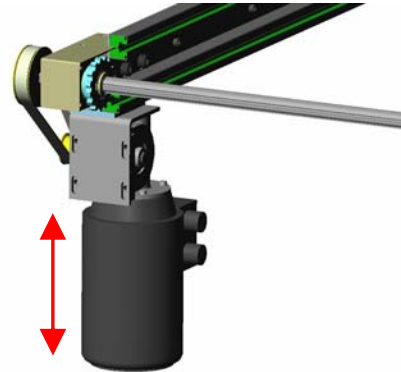

Tension device for the toothed drive belt of the chain drive

The transport chains are both at the inlet side and at the outlet side protected against access. The protecting sheet are for the protection of the operating personnel and should not be removed. The dismantling is only allowed for maintenance works and only by authorized personnel.

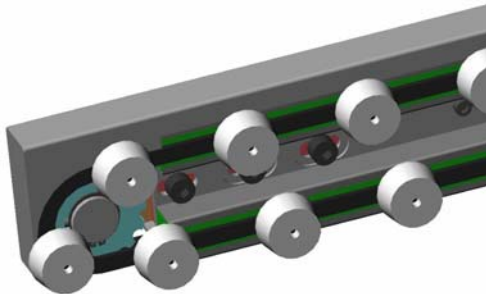

Protecting sheet inlet

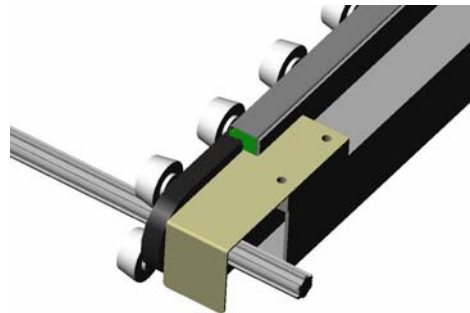

Protecting sheet outlet

5. Width adjustment system

With this equipment panels with a width of minimum 300 mm and a maximum of 760 mm can be processed. The width of the transport system has to be adjusted according to the width of the panels which have to be processed. The width adjustment is electronically set by the control system on the touchscreen.

The width adjustment system is equipped with a position sensor placed on the outlet side of the machine. This absolute position sensor keeps the actual settings even when the machine is turned off.

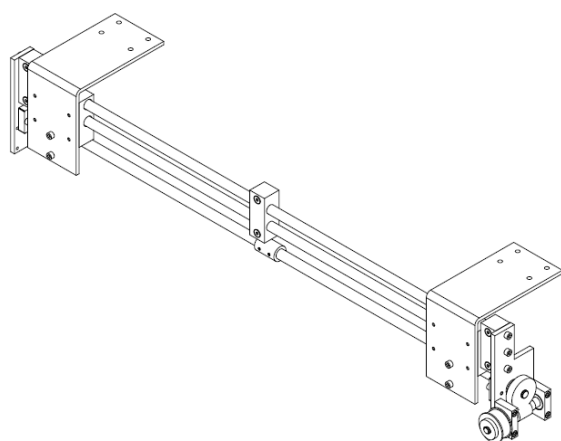
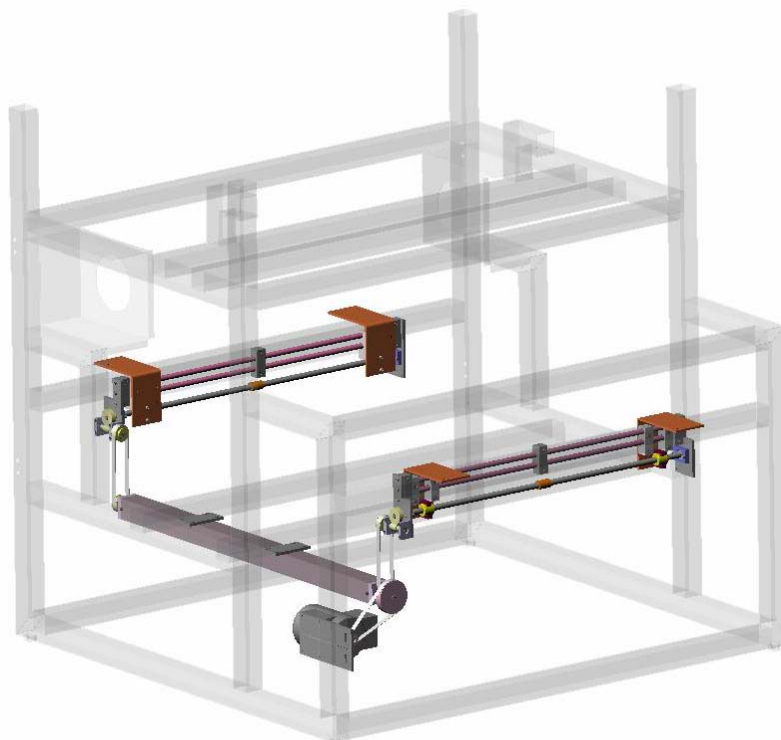

Mechanics of the width adjustment

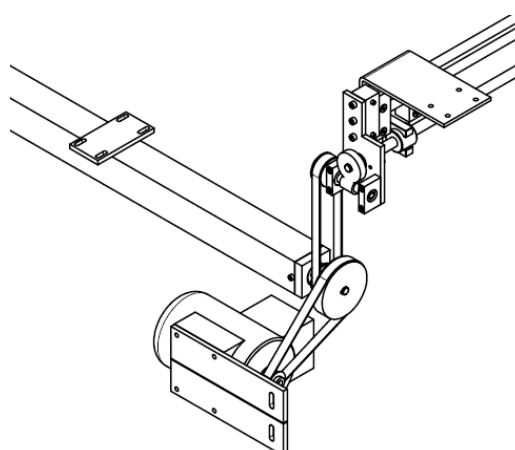

Drive width adjustment



Position sensor

Belt tension

Two steps to set the tension of the toothed drive belt:

1. Move the connecting shaft crosswise to the processing axis. Both of the toothed drive belts have to be tightened equally.
2. Move the drive unit up/downwards to tighten the drive belt.

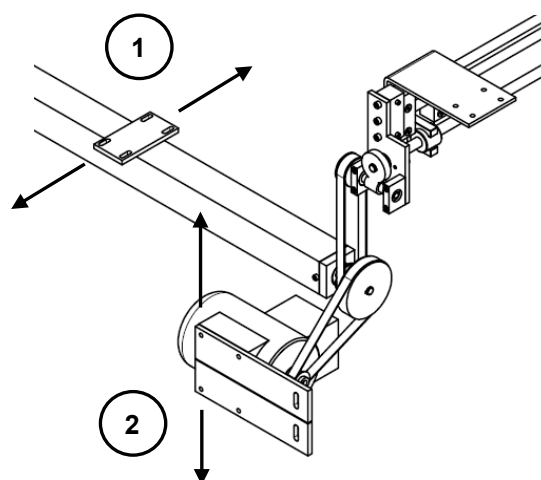

Verletzungsgefahr bei laufender Anlage:

➔ **Do not touch the belts of the drive unit. While processing the machine automatically adjusts differences from the set value.**



Grease the spindles weekly.



Don't deposit any objects in the cabin area.

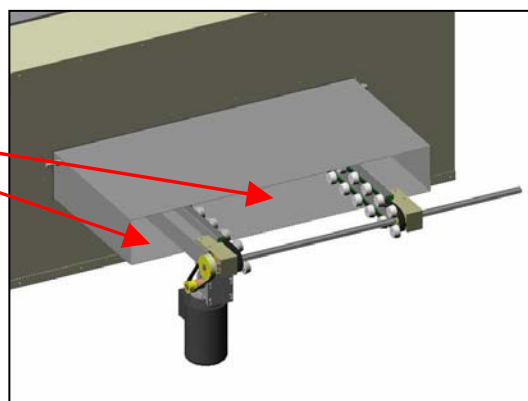

6. Sprayhead

The sprayhead is the center of the machine, where air pipes and lacquer pipes fit together in the cable drag chain. The oscillation of the sprayhead is carried out by a linear drive powered by servodrive.

The sprayhead oscillates crossline to the process axis. There's always the same movement between the end positions. The width to be sprayed conforms to the panel width, which is set in the control system.

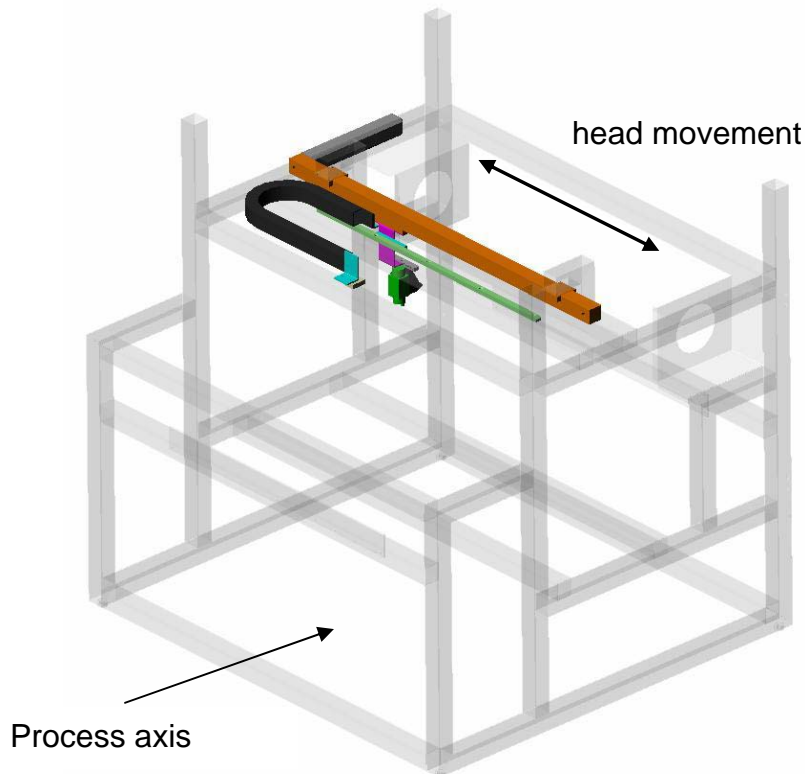

Linear drive



Servodrive of the linear drive

For cleaning the nozzle the sprayhead can be placed in cleaning position on right hand side of the oscillation track: On the touchscreen, window „system“ press „Cleaning position“

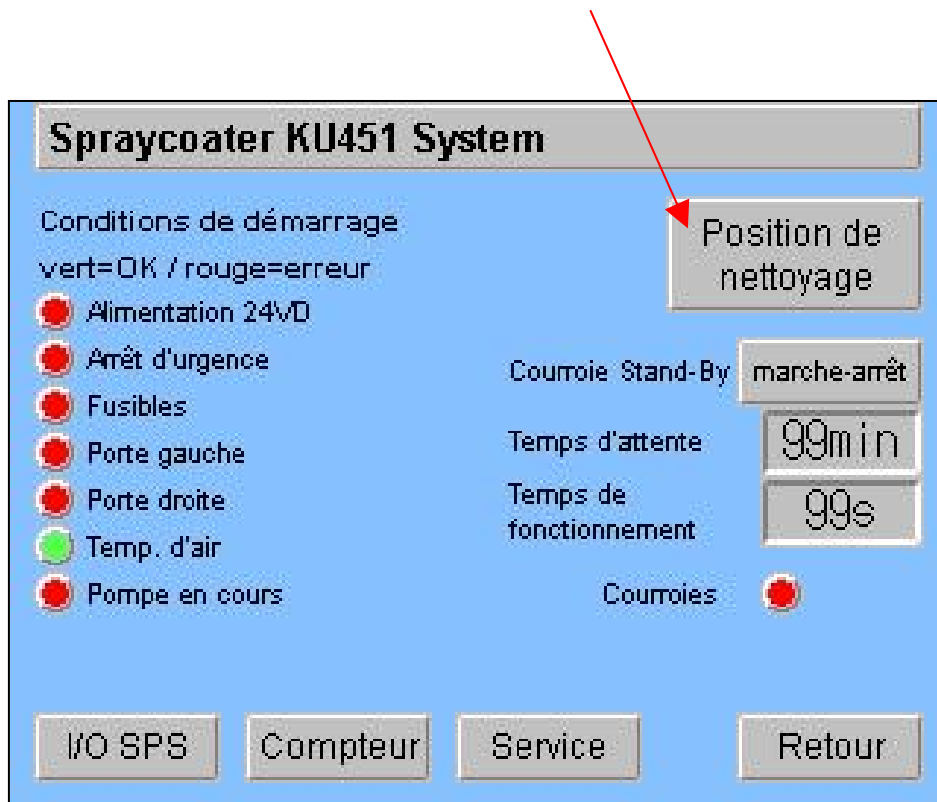

Key sequence:

In the start picture press

- „Machine on/off“
- „System“

in the picture „System“ press

- „Cleaning position“

After disassembling, cleaning and mounting of the nozzle, the sprayhead has to be brought to the center of the oscillation track.



If the sprayhead carriage once hits one of the limit switches the movement will be interrupted and an error message will be set. To reactivate please turn the machine off and move the carriage manually off that position (always move to the middle). After that turn the machine on and initialize again.

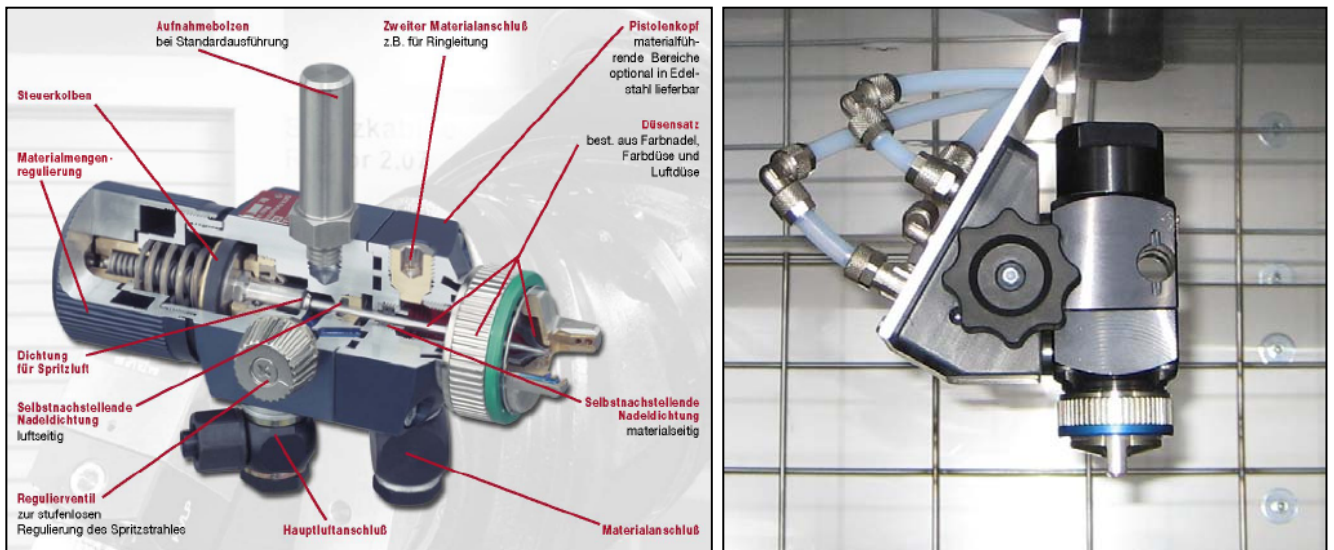

4. Changing the nozzle set

- a) Make the whole system depressurized. Remove material flow control knob and end cap with 24 mm openend wrench, remove springs.
- b) Remove the needle (a bit difficult due to the 5 sealings, if necessary use flat tongs with care).
In case of new devices proceed in the same way and take into account that the sealings stop even more the pulling out.
- c) Remove air cap by hand (do not use tongs or vise grips)
- d) Remove paint nozzle with the help of a universal spanner. When assembling the new nozzle set proceed in reverse order. Mount always the paint nozzle before the paint needle.
Warning:



Do never screw a paint nozzle on a paint needle as long as the paint needle presses against the paint needle seat. Unscrew air and paint nozzle and remove the seal retainer using a socket wrench.



For more information about the sprayhead, please see the following manual of the manufacturer.

7. Lacquer recycling system, squeegee, collecting tray

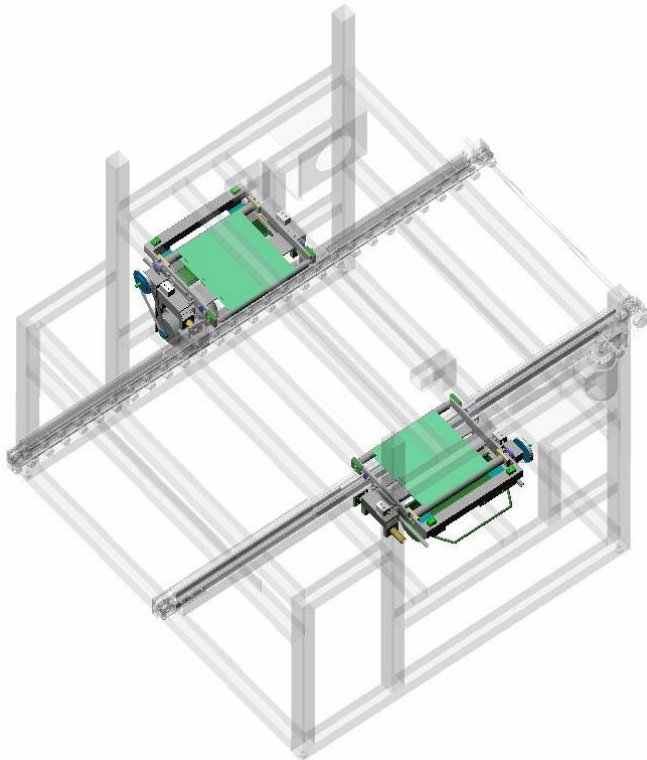

In order to minimize the lacquer losts by overspray, the machine is equipped with a patented recovering system.:
On both sides of the transport system in the region where the overspray occurs, are collecting belts placed. The belts are rotating during the spraying period and so they transport the the lacquer to their underside where it is peeled away by the squeegee and directed into the collecting tray.

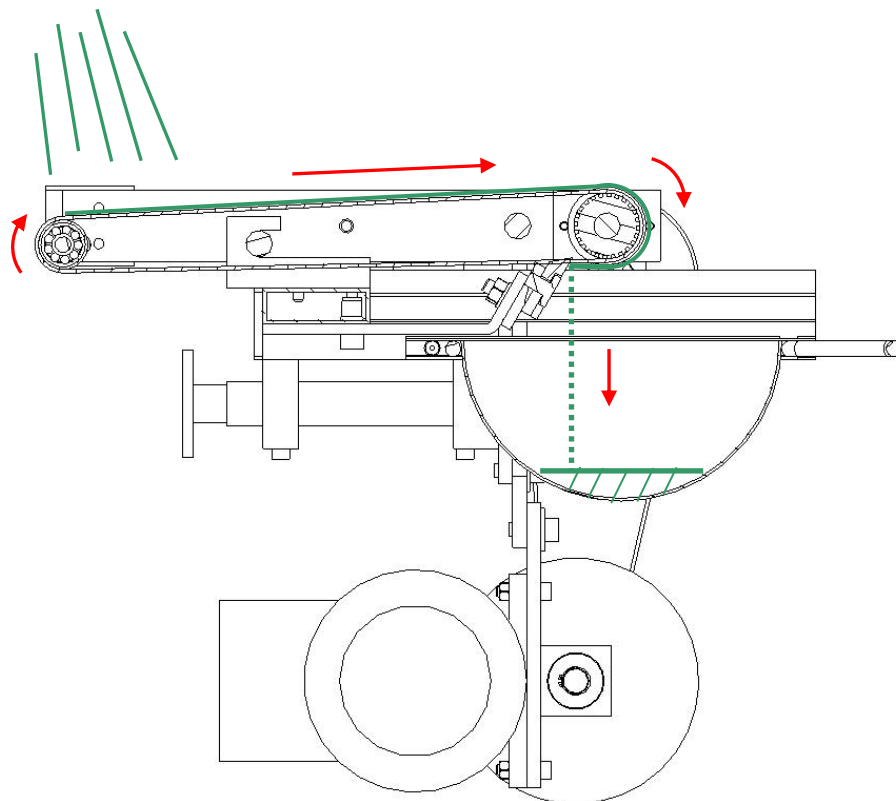

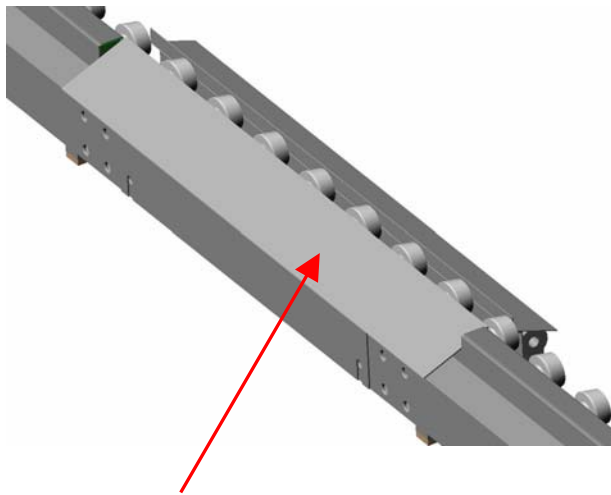

Exterior chain protecting sheet

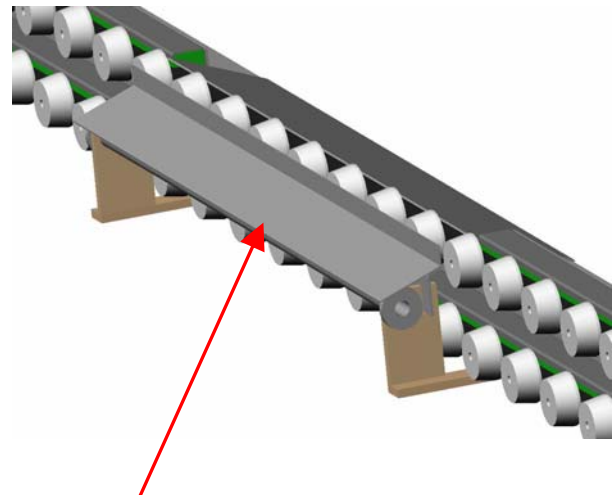

Interior chain protecting sheet

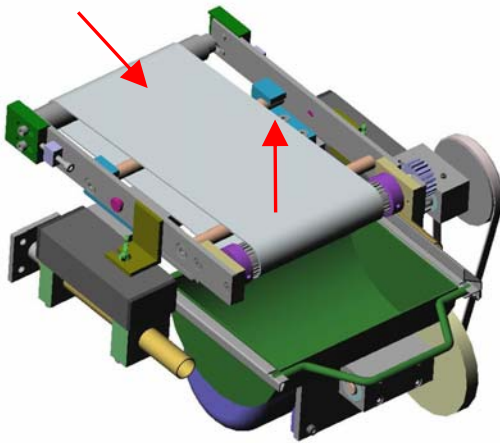

Removing the collecting belts:
Pull toward you, lift up and remove

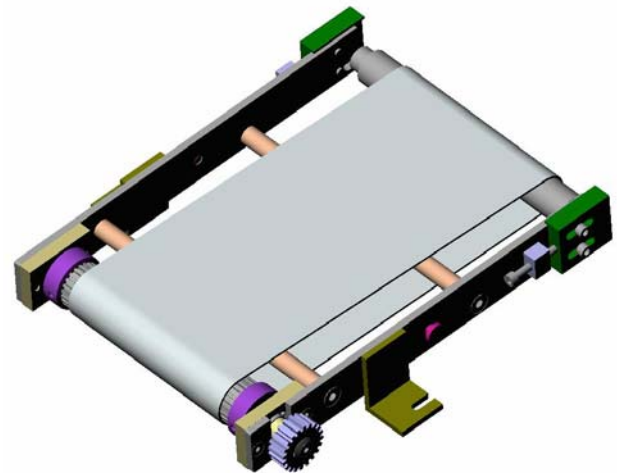

The collecting belts are one unit and can easily and without tools be removed for cleaning.

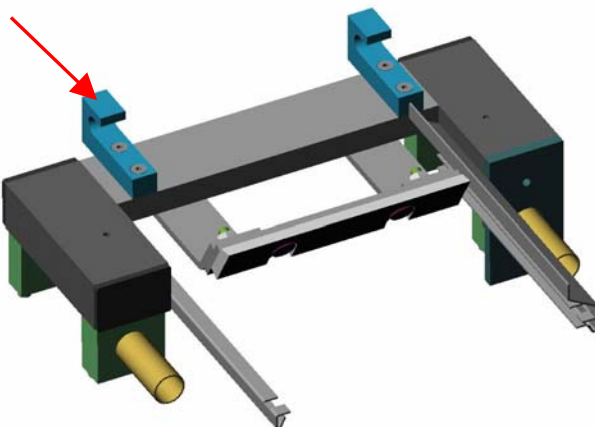

The collecting belt is to be hooked into the socket.

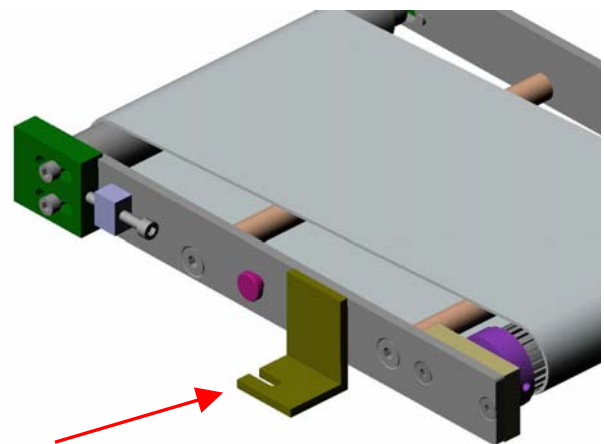

Bracket on the collecting belt.

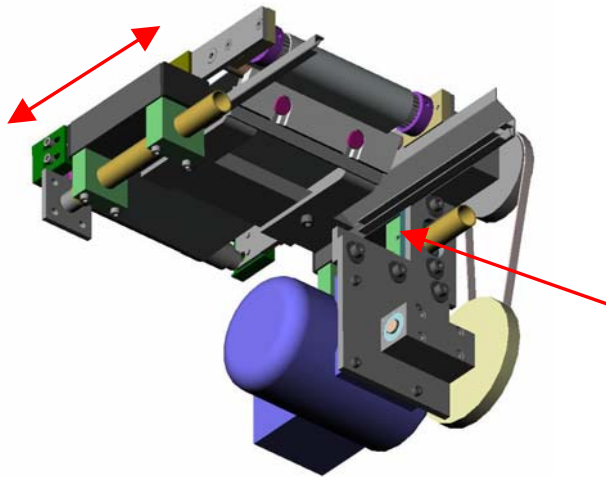

To adjust the lacquer free edges on the panels please move the whole recycling system across the processing axis.

Remove the collecting tray and unlock the screws in the aluminum carriages to set the desired position.

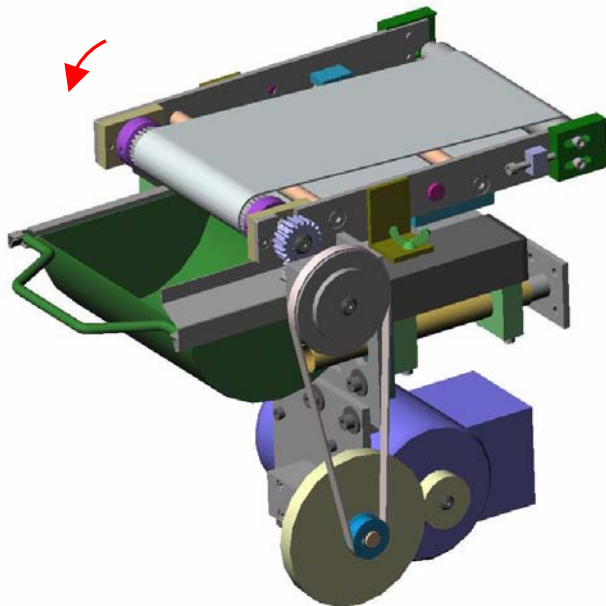

The whole lacquer recycling system is placed on the inner side of the spray cabin. This is an explosion proof zone. Therefore the drives are explosion protected.



II 2G c T4

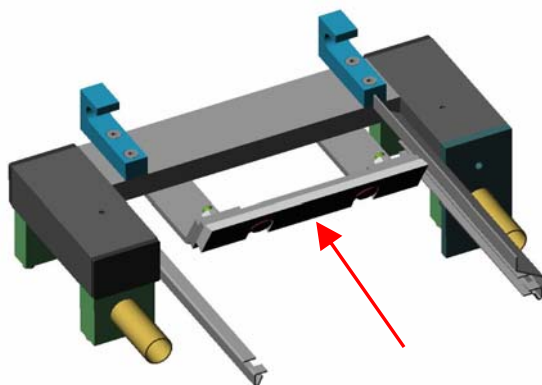

The squeegee is placed on the bottom side of the belt unit. To facilitate the cleaning, the squeegee can be dismantled by removing the screws.



The lacquer is peeled away by the squeegee and falls into the collecting tray.

Replacement of the conveyor belt

Before replacing the conveyor belt be sure that the unit is cleaned.

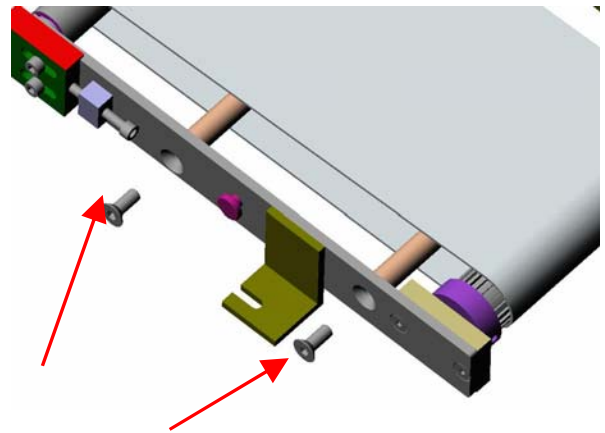
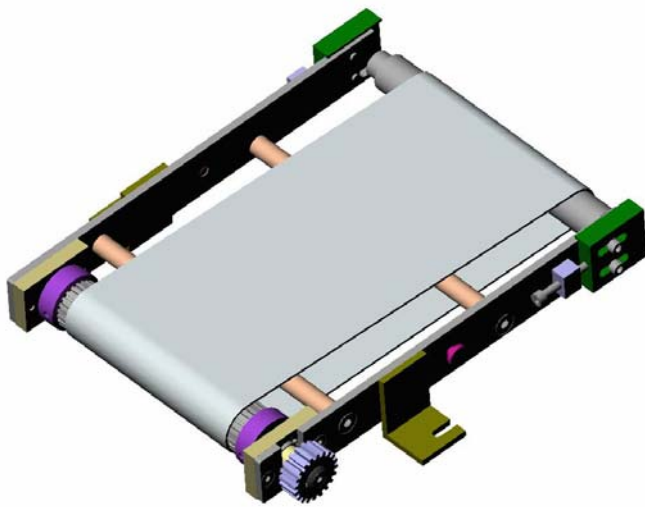

Remove the screws of the frame

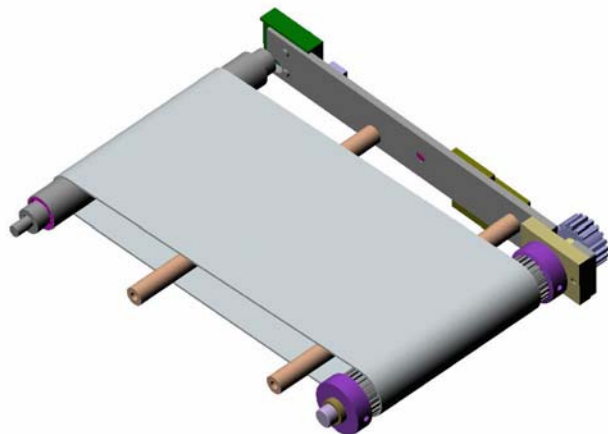

Remove the the frame

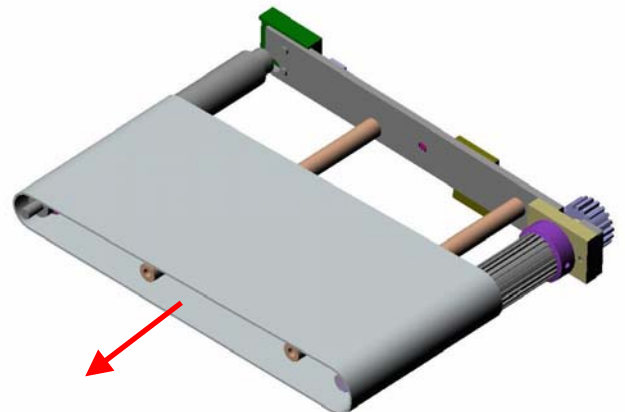

Remove the belt

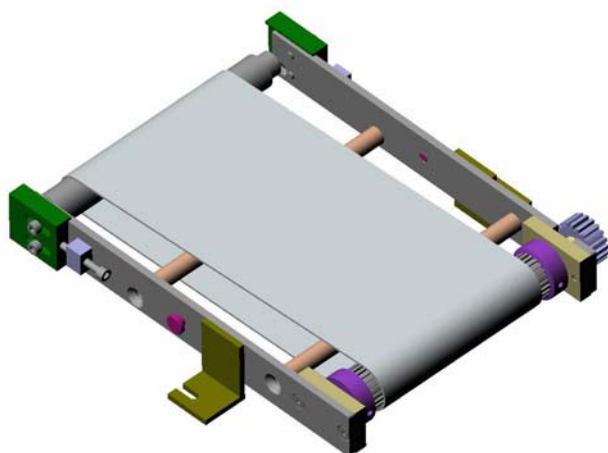

Replace the belt and reassemble the unit

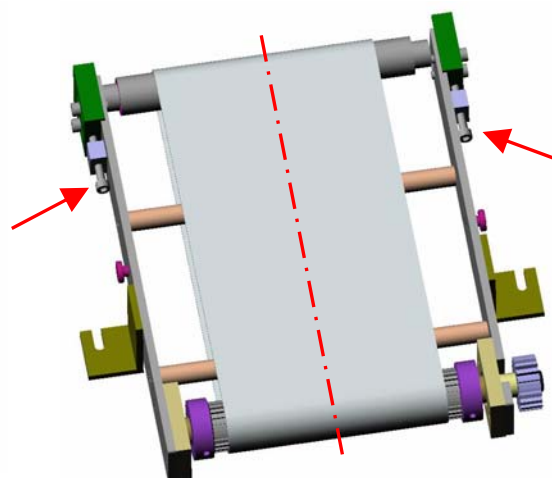

Adjust the clamp screws on both sides to make the belt moving in the centre of the unit. (best performance while running in the machine)

8. Control system

The control cabinet is placed on the inlet side of the machine. It is accessible by opening the front door upwards.



Opening the control cabinet is only allowed for authorized persons. In addition, the machine has to be currentless!

Touch-Screen



On the touchscreen all parameters can be set. An in-depth description can be found in the section: Operating of the touchscreen.

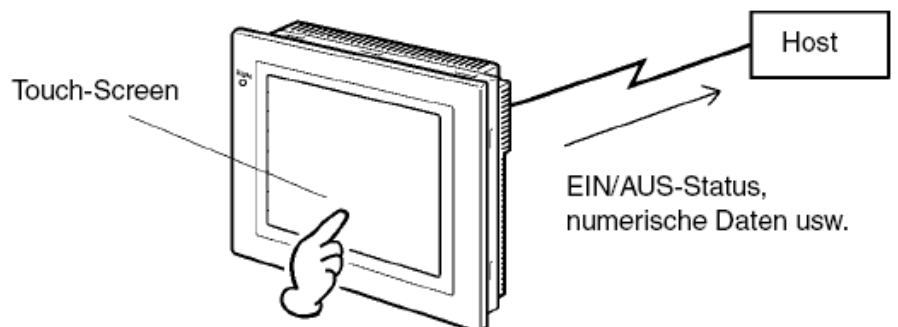

Operating the touch-screen

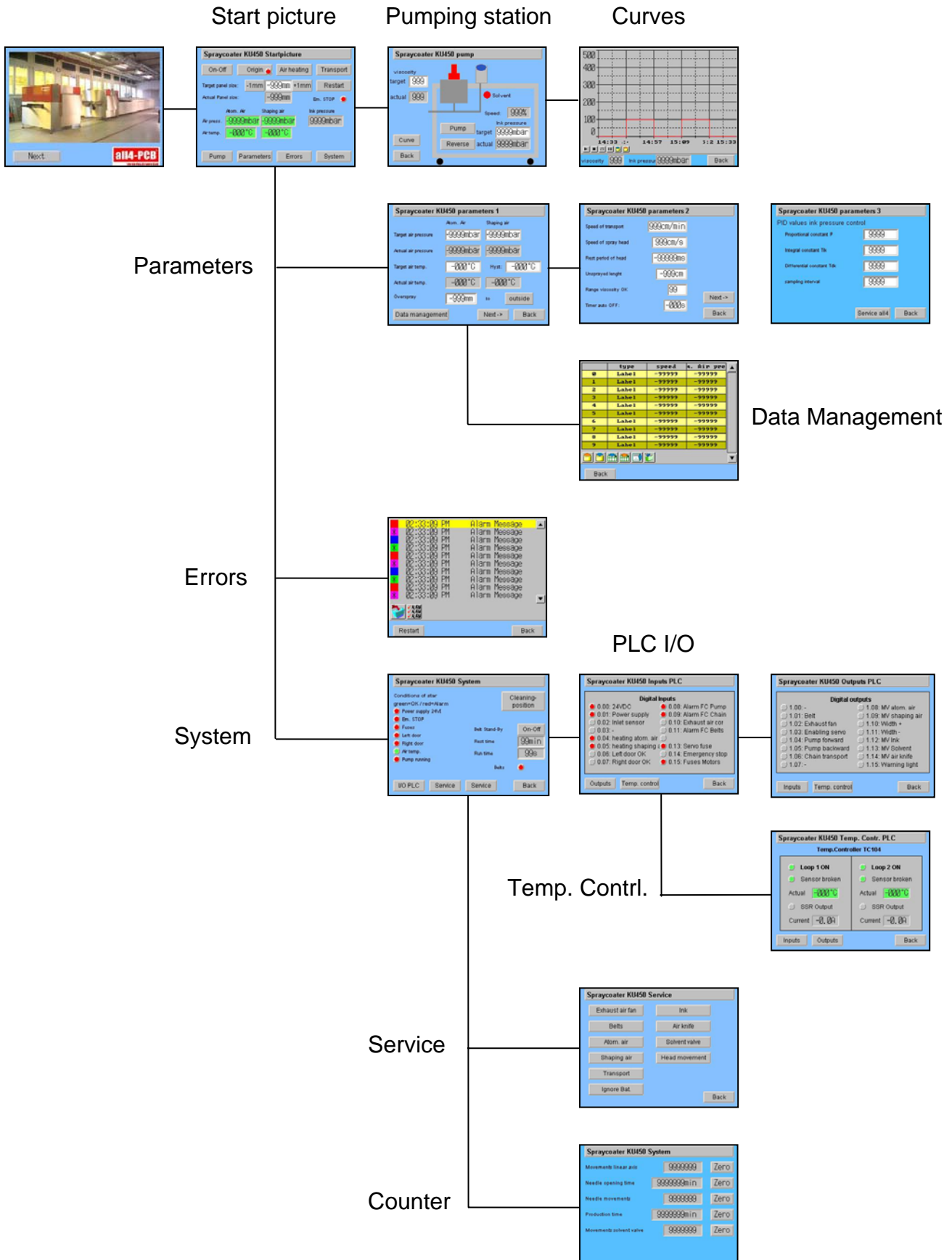

Switch-on

Switch-on the main switch to get the machine under power. The main switch is placed on the left hand side of the control cabinet on top of the machine.

On the touchscreen appears the following menu:



By pressing the desired language button, you reach the Start-up picture of the spraycoater:

Acknowledge with the key switch

Emergency stop

Start-up picture

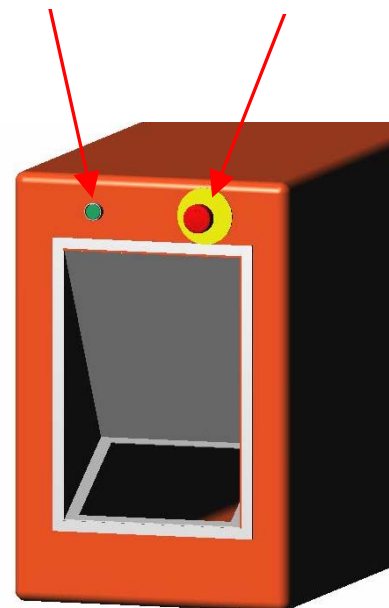
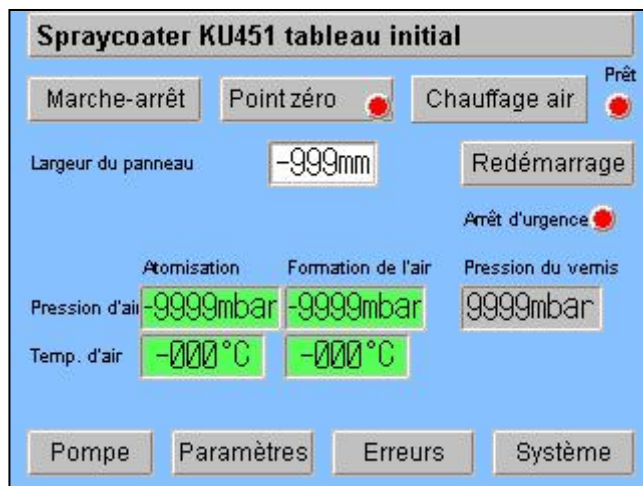

As first, press the button „On-Off“. Be aware that the emergency stop button has been released You can see it on the screen: in front of the word „Em. STOP“ there is a green or red dot. In case of a red dot, release the emergency stop button by turning it and acknowledge with the key switch.

Start-up: Turn the key switch and press „Restart“. If it does not work, release the emergency stop button by turning it!

Then press the button “Origin”. Now the spraying head moves to its zero point which is in the center of of the oscillation track. Next switch on the “Air heating”. Now the heating modules start to rise the temperature to the setpoint. This procedure may take some minutes.

As soon as the temperature setpoint of the air heaters is arrived the automatic modus will be released. Following signals indicate that the machine is ready for use:

- The “Transport” key turns yellow and can be activated now
- The air temperature displays turn green

Now press “Transport”. Simultaneous with the transport the exhaust ventilator and the oscillation of the spaying head will switch on. The machine is now in the automatic mode and the panels can be deposited on the transport system.

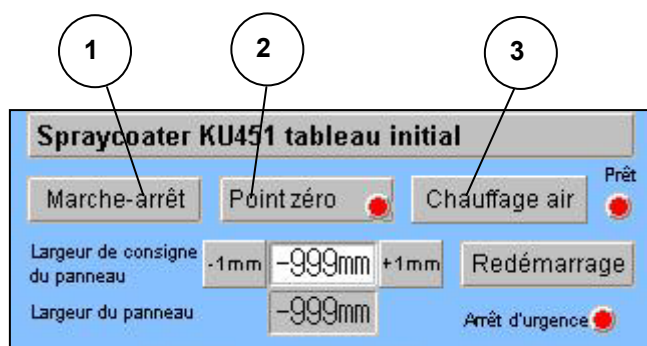

1. Push “On-Off”
2. Push “Origin” to initialise the sprayhead
3. Activate the air heating system

Should the transport not run, there is an alarm pending. In the start-up picture press the button “Errors” and check which alarm is pending. Eliminate the fault and acknowledge.

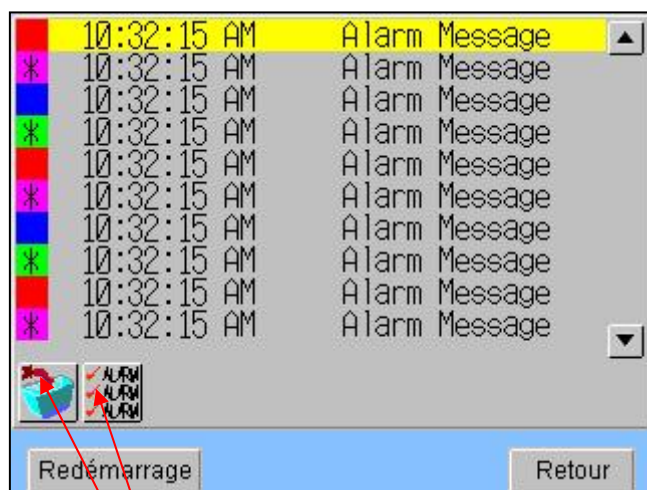

- Acknowledge alarms
- Delete acknowledged alarms

Pending alarms are marked red. After having eliminated the fault and acknowledged, the color changes from red to blue. After having eliminated all faults and acknowledged them, press the button „Restart“ and go back to start-up picture by pressing „Back“. Here you press the button „Transport“ again after having checked if all dots on the schematic illustration of the machine are green! If for example an exhaust filter has not been placed, there will not appear any alarm but the machine can not be started anyway. The corresponding dot on the screen is non green!

This check can also be done over the picture „System“.

Set panel size

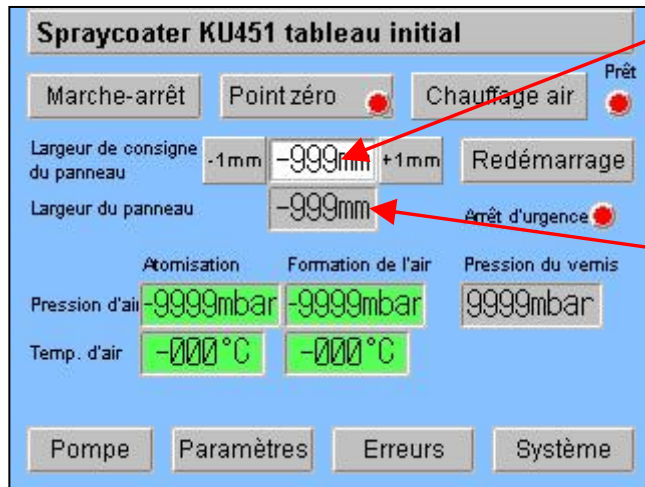

Push the panel size setting button to get to the keypad for the setting. Type in the desired panel size and push “Enter”

The current programmed panel size is shown in the window below.

For the final adjustment of the trackwidth it is possible to skip the programmed panel size in steps of 1 mm. Use “-1mm” for a smaller size and “+1mm” for a bigger size.

The actual panel size will be kept in memory. Even when the machine is turned off the value will be stored.



The programmed trackwidth will be kept in the panel, even when the machine is turned off.



It's not allowed to be in the danger area (frontside and backside of the machine) while adjusting the trackwidth.

Process values



The main process values are shown in the start picture: air pressure and temperature as well as lacquer pressure. Pressure and Temperature are in set value when the display is green. The display color will change into blue by lower actual values – red by higher actual values.



Data in set value only allow to process automatically.

This a read-only display. Please change values in the parameter window

Parameter setting

Press the button „Parameters“ in the start-up picture. The window Parameters 1 is opening and the wanted parameters can be set. By pressing „Next“ you reach the window Parameters 2.

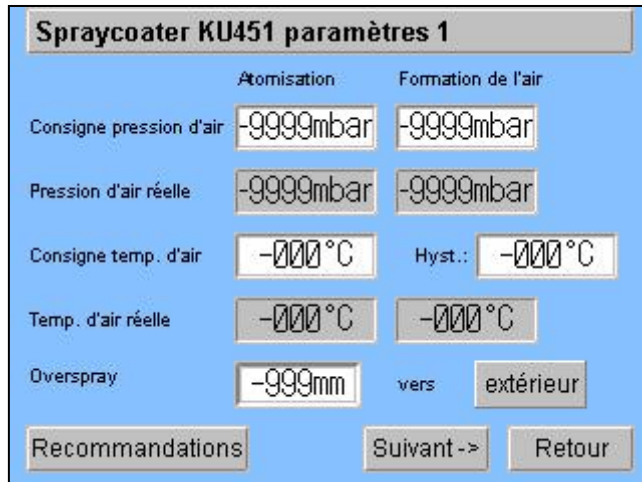

Spraycoater KU451 paramètres 1

	Atomisation	Formation de l'air
Consigne pression d'air	-9999mbar	-9999mbar
Pression d'air réelle	-9999mbar	-9999mbar
Consigne temp. d'air	-000°C	Hyst.: -000°C
Temp. d'air réelle	-000°C	-000°C
Overspray	-999mm	vers extérieur

Recommandations Suivant -> Retour

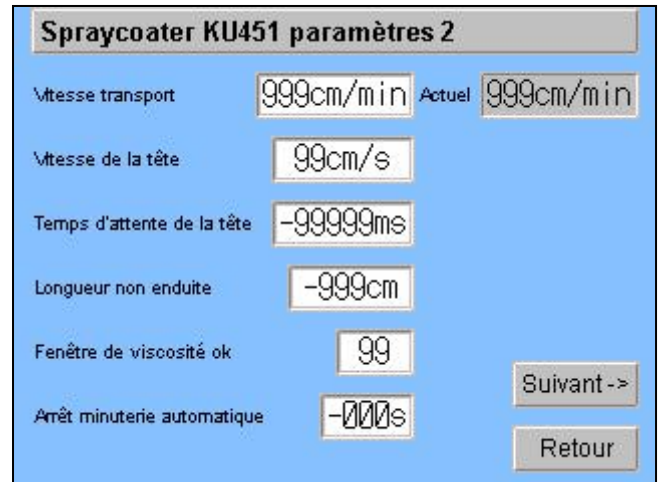

Spraycoater KU451 paramètres 2

Vitesse transport	999cm/min	Actuel 999cm/min
Vitesse de la tête	99cm/s	
Temps d'attente de la tête	-99999ms	
Longueur non enduite	-999cm	
Fenêtre de viscosité ok	99	
Arrêt minuterie automatique	-000s	

Suivant -> Retour

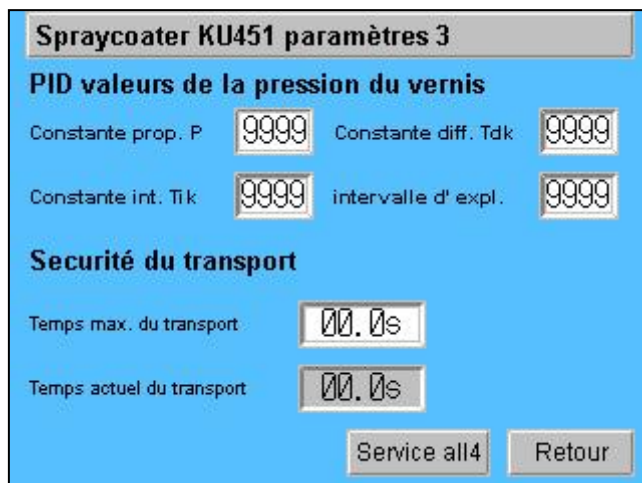

Spraycoater KU451 paramètres 3

PID valeurs de la pression du vernis

Constante prop. P	9999	Constante diff. Tdk	9999
Constante int. Tik	9999	intervalle d'expl.	9999

Sécurité du transport

Temps max. du transport	00.0s
Temps actuel du transport	00.0s

Service all4 Retour

The PID controller regulates the lacquer pressure. The machine is programmed with standard settings.

We recommend not to change these settings!

P= 4000

Tik= 5

Tdk= 1000

Sampling intervall= 10

The function of the transport system is controlled by its security system. The Input is taken by a sensor. The actual cycle time between two pulses is visualized on the grey display. A limit to be set on the white display specifies the maximum overtime to get the next impulse. Once the limit is exceeded the machine will be turned off immediately.

Setting range of the Parameters

The values of the different parameters has to be determinated and optimized together with the supplier of the lacquer.

Parameter	Min.	Max.	Unit	Description
viscosity	0	500	-	The lower the value the thicker the lacquer. A thin lacquer leads to a better surface because the single drops better flows together. But the edge coverage is worse because the lacquer has more flow off the edges.
lacquer pressure	0	2000	mbar	The pressure of the lacquer sets the value of lacquer on the board. The specified setpoint of the pressure is regulated by the rotation speed of the pump.
atomisation air pressure	1800	5000	mbar	The higher the pressure of the atomisation air the finer is the atomisation of the lacquer drops and therefore the more equal is the spray surface. A higher pressure of the atomisation air leads to more dust and more pollution inside the cabine.
shaping air pressure	1800	5000	mbar	The form of the spray jet is set by the pressure of the shaping air. A lower pressure produces a spray jet like a spot. A higher pressure leads to a long drawn spray jet. The pressure of the shaping air should be set equal to the atomisation air pressure.
air temperature	20	140	°C	The air temperature influences the viscosity of the lacquer. The higher the temperature of the shaping and atomisation air the thinner is the lacquer while being atomised, and the smaller is the size of the lacquer drops. A higher air temperature causes the lacquer temperature to rise. This leads to partial volatilisation of the solvent.
hysteresis	5	20	°C	Tolerance range where the temperature can vary before automatically being reset.
Overspray	0	150	mm	The range to be sprayed is depending on the board size and on the programmed overspray value. Example: a board with 450mm width and an overspray value of 60mm result in a range to be sprayed of $450+2*60=570$ mm. On both sides 60mm will be spayed "over" onto the lacquer recycling belt. The overspay can also be set to the inside of the board. This results in following range to be sprayed: $450-2*60=330$ mm.
speed of transport	0	160	cm/min	The speed of the transport is closely depending on the speed of the sprayhead. A too fast transport speed results in a zigzag spraying pattern on the panels.
speed of spray head	0	160	cm/s	
rest period of head	0	10000	ms	The programmable delay at the reversal point of the sprayhead carriage.
unsprayed lenght	1	80	cm	The distance not to be sprayed on the dummy boards



The ideal parameter setting has to be established with the lacquer manufacturer.

Button „Data Management“

In the window „Parameters“ press the button „Data Management“. You will be asked for a password.. The password is 123. Type it and press „Enter“. The following windows opens:

	Type	Vitesse	Position atomi
0	Label	-99999	-99999
1	Label	-99999	-99999
2	Label	-99999	-99999
3	Label	-99999	-99999
4	Label	-99999	-99999
5	Label	-99999	-99999
6	Label	-99999	-99999
7	Label	-99999	-99999
8	Label	-99999	-99999
9	Label	-99999	-99999

Retour

Here you have the possibility to store the parameters for a specific lacquer system. After having found the optimum parameters for the lacquer XY, you can store them here. First you have to enter a name in the column „Typ“ e.g. lacquer XY. Should the same lacquer be processed later, you can just recall the parameters and send them to the command. See below.

Transferring the parameters from the command into the window „Data Management“

7	Label	-999
8	Label	-999
9	Label	-999

3 2 1

1. Press this button and a keyboard will appear. Type the name and Press „Enter“
2. Press this button to transfer the parameters from the command into the recipes
3. Save the transfer
4. Press “Back”

Transferring the parameters from the „Data Management“ into the command

7	Label	-999
8	Label	-999
9	Label	-999

1 2

1. Tap the name on the number column
2. Press this button to transfer the parameters from the memory into the command.
3. Press “Back”

Delete recipes



1. Tap the recipe
2. Tap the trash
3. Tap save

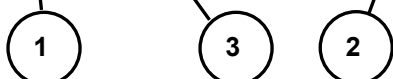

Already memorized parameters which have been modified, again memorize

Even if it is possible to change parameters directly in the window „Data Management“ **don't do it!** This has exclusively to be done in the window „Parameters“

If for a specific lacquer type some parameters have been modified in the window „Parameters“, they have to be stored again in the window „Data Management“



1. Tap the existing recipe
2. Press here to transfer the new parameters from the command into the memory
3. Save
4. Back

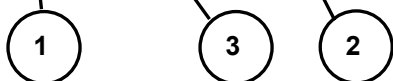

Window „System“

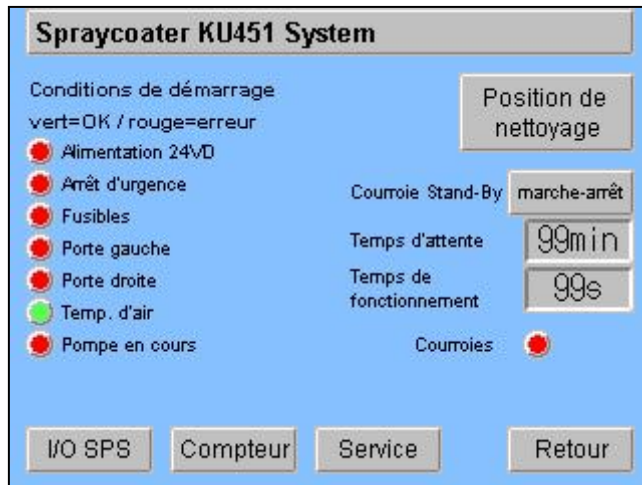

The machine can be handled manually in the system window.

All positions with a red dot inhibit the Start-up of the machine.

The sprayhead will be moved to the cleaning position by using the “cleaning position” button.

The cleaning position is located on the operator side of the machine.

Window I/O PLC

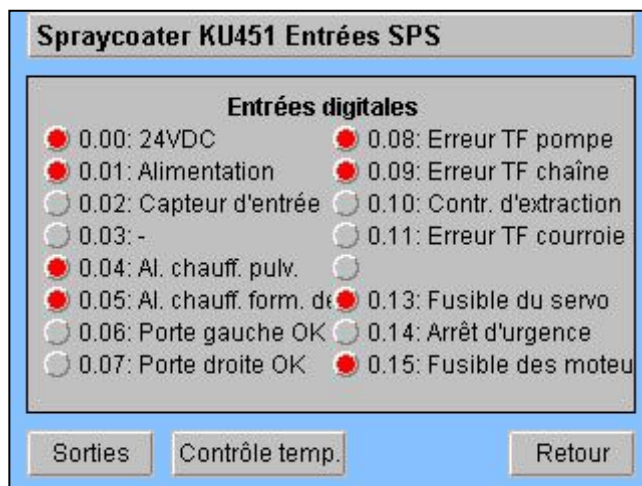

Here is the state of all digital I (green) and O (red) of the PLC shown.

By pressing „Temp. Control“ you reach the window „Temperature Control“.



Temperature Controller

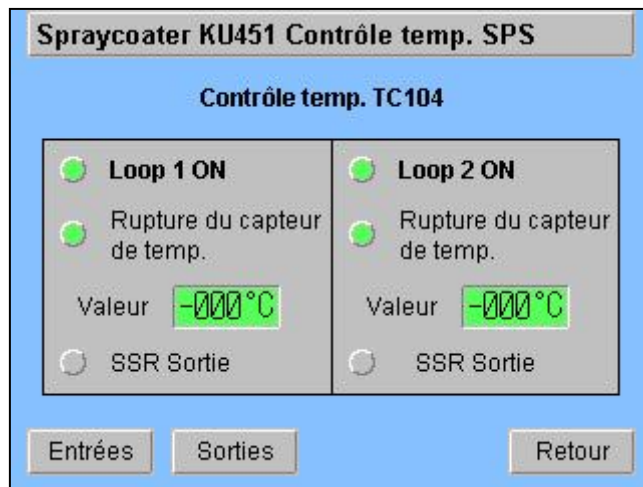

Here you can check the situation of the temperature probes:
 Probe OK, green
 Probe not working, red

“Loop” is an indicator whether the heaters are turned on or off.

The temperature sensor PT-100 is electrically controlled. If there is no more resistance the machine displays a sensor brake. This will be handled like an emergency stop.

The actual value shows the actual temperature

The “SSR-Output” displays the controlling of the semi-conductor relay. Green stands for heating.

Counter Window



The counter of the spraycoater registrates all the process-movements like:

- Movements linear axis
- Needle opening time
- Needle movements
- Production time
- Movements solvent valve

All these values can be reset. This operation is password-protected.

Service mode

If in the start-up picture you press „System“ then „Service“ the following window opens:

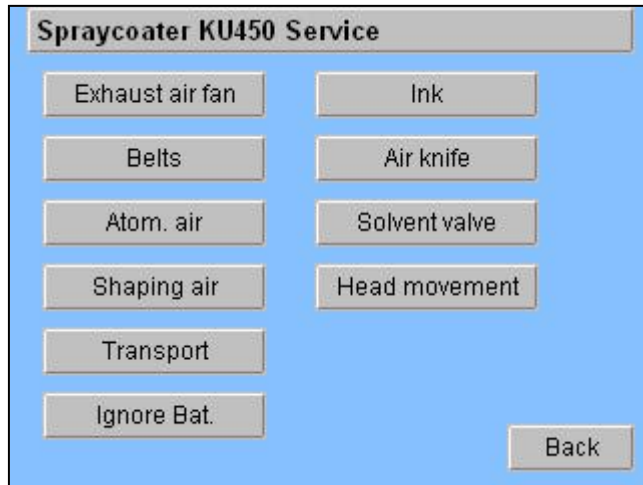

In this window it is possible to start-up all single components as long as there is no alarm pending. Certain faults like exhaust filter not mounted, air extraction control or lacquer temperature are bridged and do not avoid the start.



Machine may only be used by trained or instructed personnel.

While handling the machine manually be sure that nobody is located in the danger areas.

9. Pneumatic control system / Function of the different valves

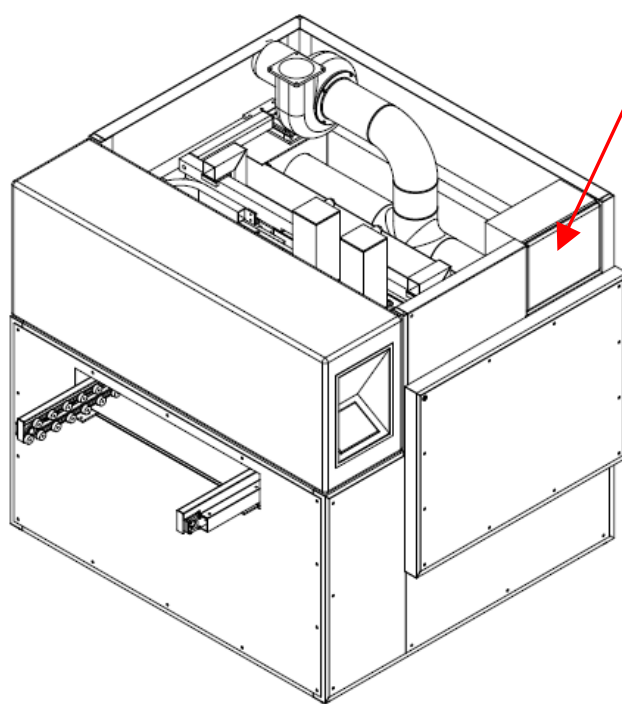

The pneumatic control system is placed on the right hand side, on top of the machine.

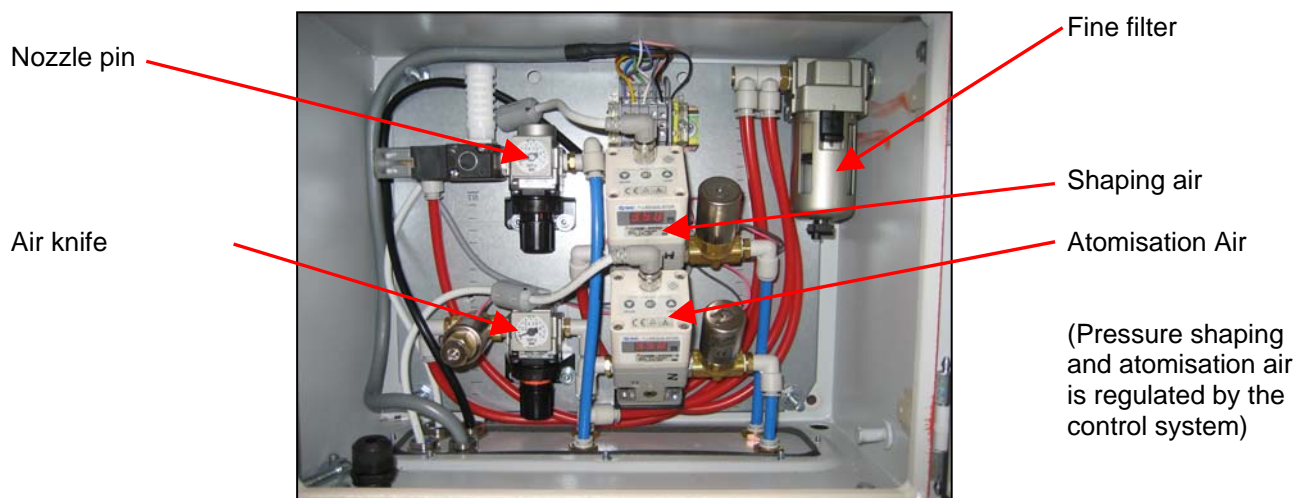

The desired atomisation and shaping air pressure is set on the touchscreen and transferred to the electronic command. An in-depth description can be found in the section: Operating of the touchscreen.



By default the machine is not equipped with an air service unit. The air must be provided by the customer fulfilling following conditions:
The air must be dry, filtered and free of oil and grease
Pressure 6-7 bar
Flow rate 500 lt/min

Adjustment of the Wet Weight

The wet weight which has to be applied depends very much on the topography of the pattern and of the lacquer which has to be used. It is a big advantage to make preliminary trials with the supplier of the lacquer in order to determine the correct parameters.

Procedure to measure the wet weight:

A board with well known dimensions is placed on a balance with an accuracy of 0,1 gr and tared. Place a dummy on the transport system, then without gap the tared board and finally again without gap a second dummy. As soon as the tared board is leaving the coater, take it and place it on the balance again. Read the weight and convert it to 1 m^2

In case of very high conductors it can be an advantage, instead of applying one time a high wet weight, to coat 2 or more times with a lower wet weight. It will be easier to dry the surface and you will get a better quality.

In any case the edge coverage and filling between the conductors has to be verified with cross sections after exposing and polymerisation!

Lacquer pumping station KU 550

The lacquer pumping station is separate unit and is built to deliver the lacquer.

The pumping station consists of pump, filter, viscosimeter, lacquer container and solvent container. Piping and wires are brought together in the centre and lead in a flexible tube which is connected with the spraycoater.

A stainless steel frame carries all the components. The pumping station is movable.

One sprayhead and one pump is the standard equipment of the spraycoater.

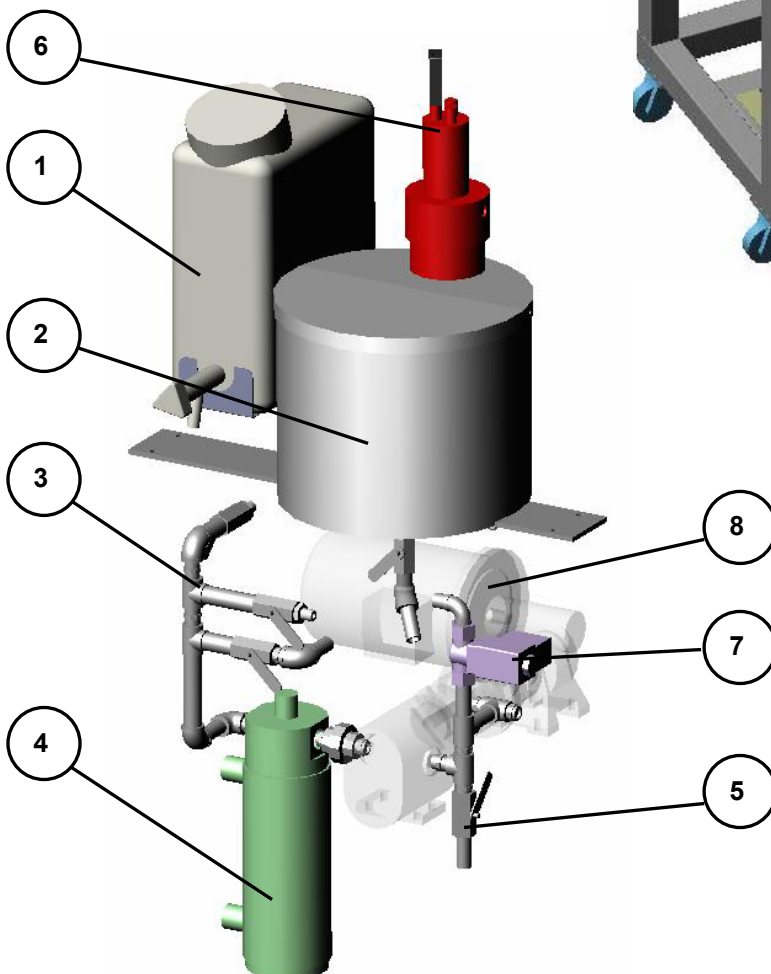
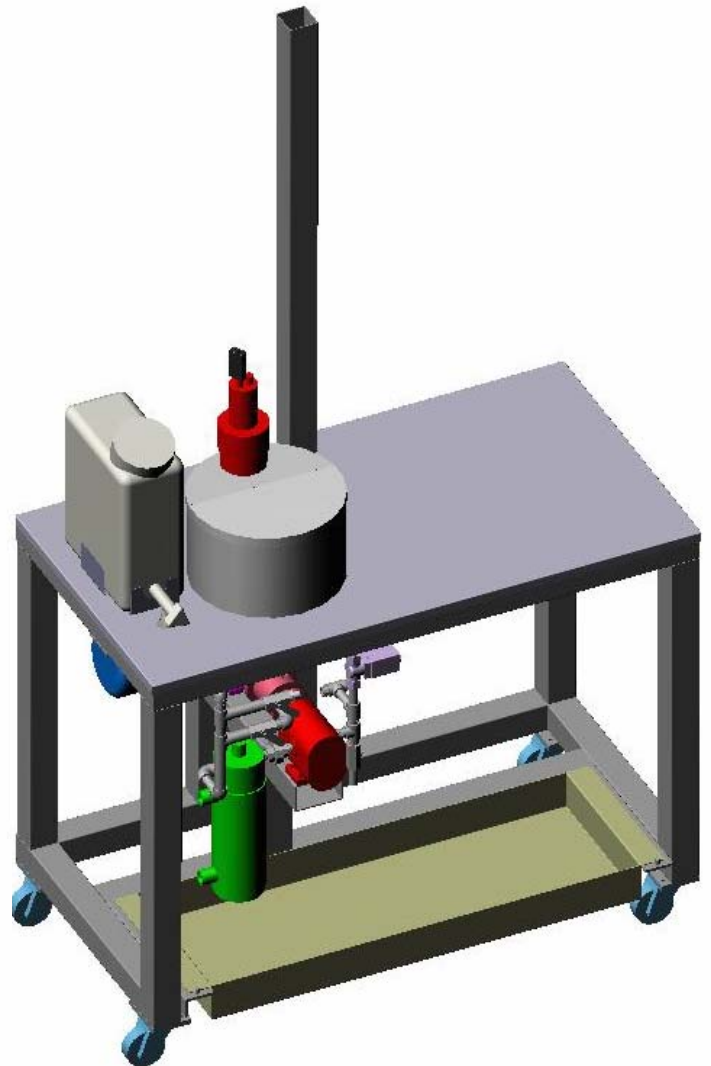

1. Solvent container
2. Lacquer recipient
3. Pressure line
4. Filter
5. Intake line
6. Viscosimeter
7. Magnetic valve
8. Pump

Piping

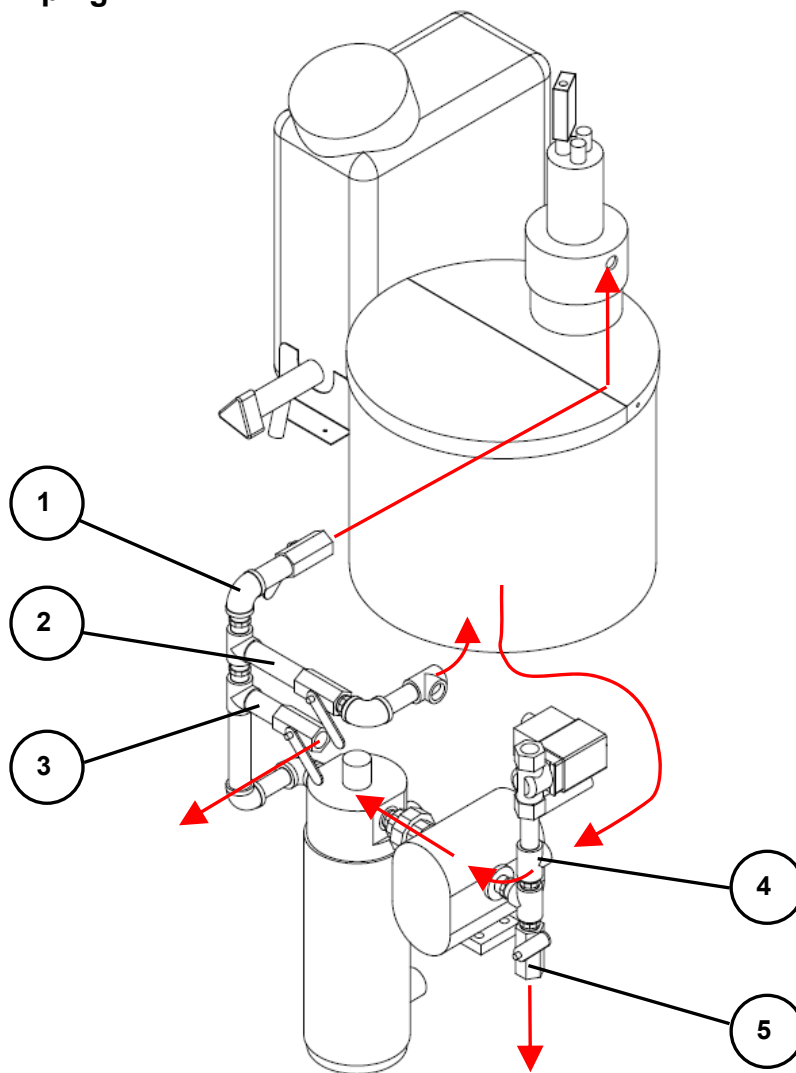

1. Inlet viscosimeter
2. Bypass
3. Lacquer pressure line to spraycoater
4. Inlet lacquer from container
5. Outlet lacquer

Pump

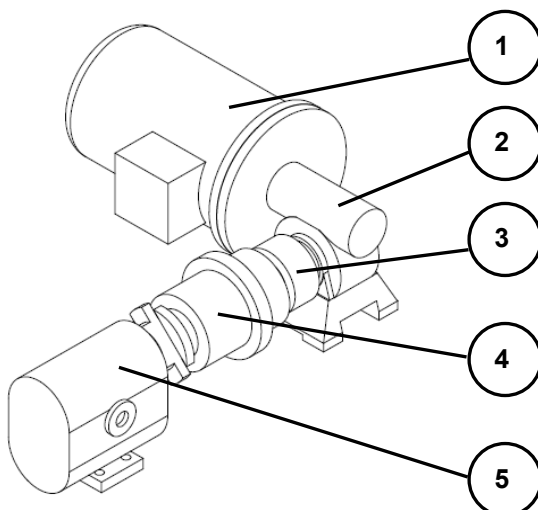

1. Drive
2. Worm gear
3. Rotex coupling
4. Magnet coupling
5. Gear pump

Lacquer circulation

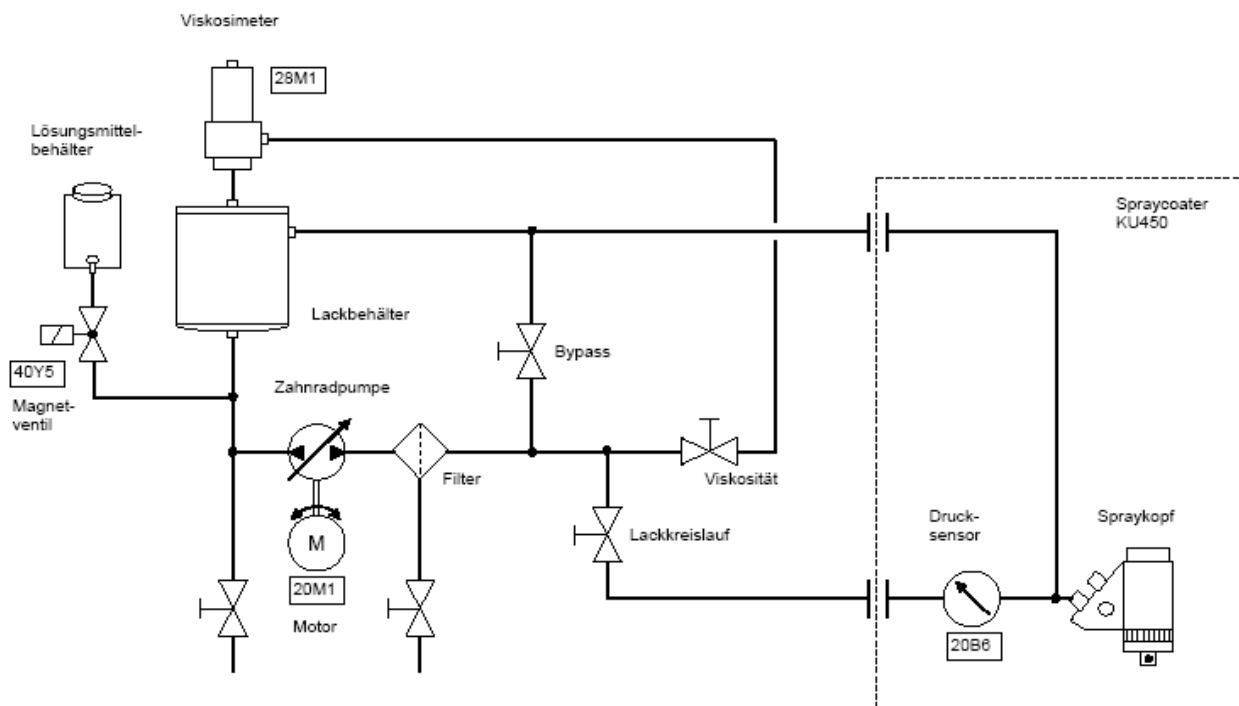

The lacquer circulation between Conditioning Station and Spraycoater consists of three different cycles:

- Main cycle to the spray head
- Bypass cycle
- Cycle of Viscosimeter

On the main cycle the lacquer circulates via pump and filter to the spray head in the Spraycoater and back. A gear pump is responsible for the operating pressure of the lacquer within the reservoir.

The discharge capacity is controlled by a frequency motor. The subsequent filter is responsible for filtering out foreign matter from the lacquer.

To lower the dynamic load of the pump there is a bypass system that leads the lacquer back to the reservoir. The volume can be handled manually.

For the use of the Viscosimeter there is a third cycle to deliver the lacquer into the measuring head and back to the reservoir.



The lacquer does not pass through the spray head all the time! The lacquer only passes while spraying.

Viscosimeter KU865



The viscosity of the lacquer processed in the lacquer conditioning station is continuously monitored and controlled by the viscosimeter KU865.

The viscosimeter mounted to the lacquer recipient continuously measuring the viscosity transferring the measured value to the evaluation unit. If the specified viscosity is exceeded a proportioned amount of solvent is fed to the material reservoir. The can for the solvents is next on the conditioning station.

One part of the lacquer is extracted from the pump pressure side and fed through a hose to the measuring head. Within the measuring head one part of the flow is directly fed via the discharge pipe in order to avoid settling of solid particles contained in the lacquer reducing the line cross-section. The remaining lacquer (approx. 10 – 100 cm³/min) is flowing through the measuring head and through the overflow cut-out into the central discharge pipe.

A vent hole can be found in the uppermost "bell" position of the rotor and a discharge hole in the "sump" position of the stator. As a result, the system is vented automatically when activated or if air bubbles are in the lacquer. The system is completely emptied when the lacquer pump is switched off. Depending on the viscosity of the lacquer its "shearing viscosity" is changed.

A rotor is turned by a DC motor with stabilized DC voltage. Depending on viscosity the section modulus of the motor shaft is varied changing the rotor speed. This speed is transformed into voltage by a tachogenerator and transferred to the PLC.

With the help of a visualization software on the PC the nominal value is entered into the PLC. In the PLC the opening pulses of the solvent dosing valve are determined via a proportional control. The valve is triggered by a relay.

When using a PC the measured values can be directly registered. We recommend to make an additional connection for a PT100 sensor to the PLC. As a result, the lacquer temperature can be put down parallel to the viscosity recording.

Additionally, the injected amount of solvent can be displayed graphically on the screen. Individual charts can be loaded to the screen, stored on diskette or printed out.

The housing, the rotor and the accompanying outer shell for motor and stator of measuring head are made of anodized aluminium. The solvent-proof lacquer supply line is inserted into the side screwing.

The stainless bushings are sealed with o-rings. The control cable for motor and tachogenerator is shielded.

Touch-Panel

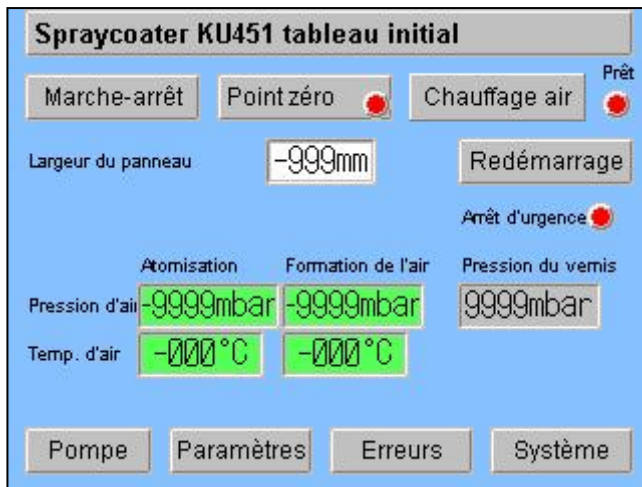

Press "Pump" in the startpicture

Pumping station

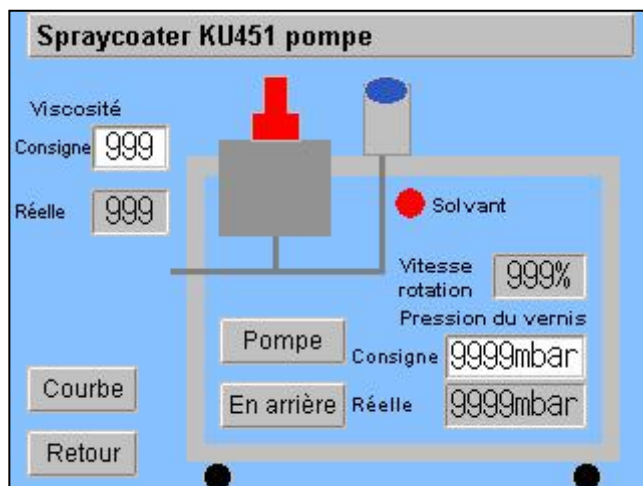

Press "Pump" to circulate the lacquer. The drive slowly starts rotating and steps up till the desired lacquer pressure is achieved.

Setting lacquer pressure

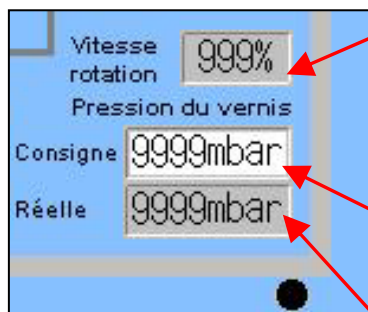

The actual rotation speed is shown in this window.

Be sure that the value averages about 60%.

Enter the desired pressure in the window for target value

Window for actual value

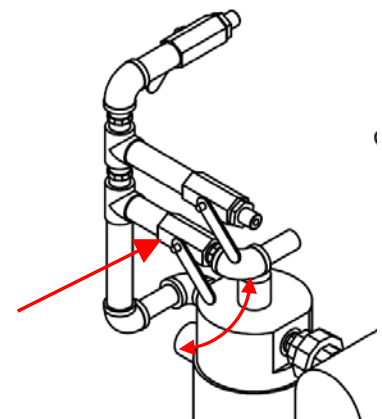

It's not possible to enter the rotation speed. The rotation speed is controlled by setting the bypass plug valve manually.

Viscosity regulation



The viscosity of the lacquer is controlled by the viscosity regulation. If the actual value varies from the target value the system adds solvent into the lacquer circulation. This operation is only able to add solvent. It's not possible to remove solvent from the system. The values are not absolute. The rotor in the viscosimeter measures the resistance that occurs while lacquer passing the housing. A scale from 1 to 500 allows to interpret the viscosity.

Setting the viscosity

Fill Fresh lacquer into the lacquer recipient and start the pump. Find out the desired viscosity by measuring the lacquer conventionally (DIN-pot measurement in seconds). When the right setting is found check the actual value. Now type the actual value into the target value window. Further differences from the target value will now be regulated by adding solvent to the system.

Pressure Curves

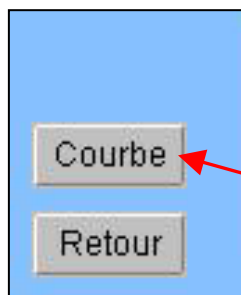

Push the "curves" button to get to the lacquer pressure visualisation

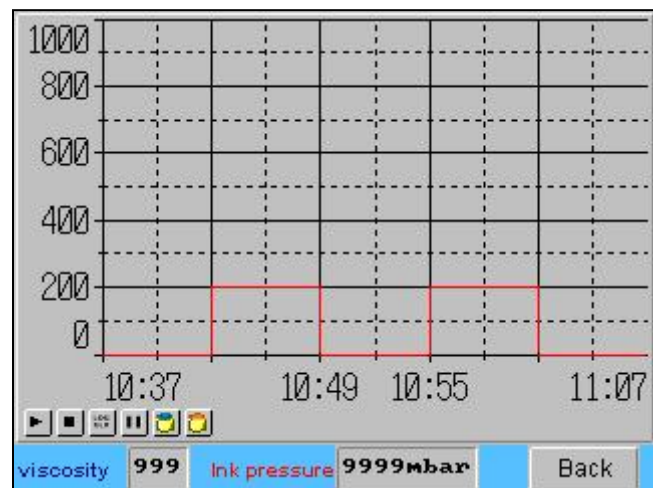

Setting Range of the Parameters

Parameter	Range	Units
Viscosity	0-1000	number
Pressure	0-6000	mbar

- The viscosity is not expressed in e.g. seconds but in a number because it depends on the type of lacquer in use. The real measured viscosity can later be allocated to this number for a certain type of lacquer.
- Example: Lacquer XY: Viscosity measured with a YZ cup (DIN, Ford etc.) with an outlet diameter of A, is 35 seconds at 24°C and corresponds to a number of 500.
- It is recommended to register the measured values in a chart in order to revert them later.
- :

Example

Lacquer type	Cup	Number	Time/Temp.
Lacquer XY	DIN Cup 4mm	500	35 s/24°C

usw

A similar chart can be elaborated for the pump pressure corresponding to a certain wet weight:

Example

Lacquer type	Viscosity	Pump pressure	Wet weight
Lacquer XY	35s/24°C	870 mbar	125 g/m ²

Cleaning procedure:

Don't forget to drop the lacquer in the sprayhead while changing the lacquer or cleaning the machine. For this purpose move the sprayhead to the maintenance position and activate the nozzle pin (main menu / system / service / ink) and let the lacquer run down in a can. Make sure that a can is positioned below the sprayhead. Afterwards clean the whole system with solvent.



Never atomize solvent on the machine. Otherwise the solvent vapor could catch fire or even explodes.

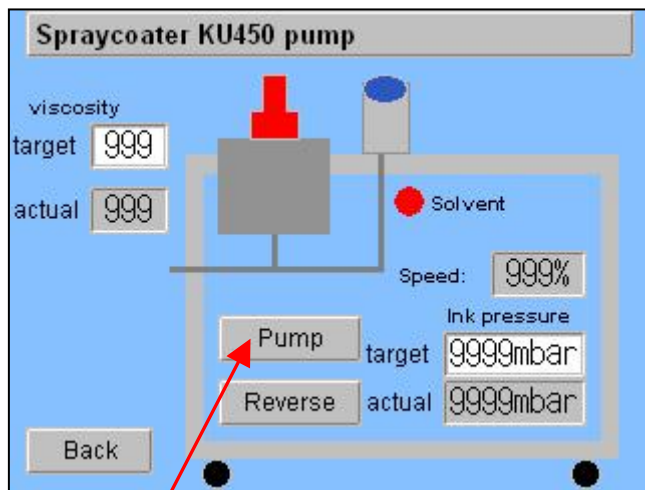

On the touchscreen select the window „Pumping station“

- Switch off pump
- Place a container with a big enough capacity under the drain valve and the filter housing. Open the valve of the lacquer recipient and drain.
- By means of the button „Reverse“ on the touchscreen let the pump rotating backward in order to recover as much lacquer as possible.
- Open the valve of the filter housing and drain as well.
- When no more lacquer is flowing out, close all valves, close the container with the recovered lacquer and place it on a safe place for reuse.
- Remove the lacquer degassing sheet from the recipient.

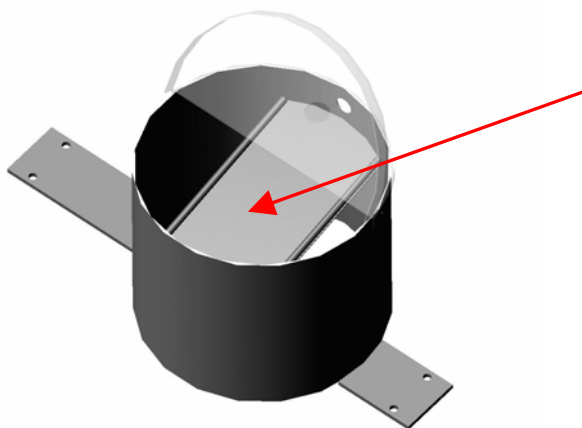

Lacquer degassing sheet
In the lacquer recipient
Spray coater KU451 vers. 2.0 e

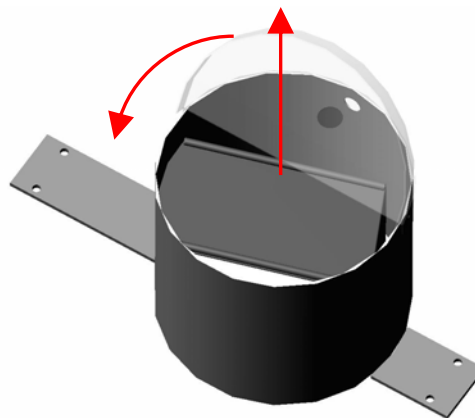

Rotate the sheet 90° and lift it out of the recipient.

Pour solvent into the lacquer recipient and switch on the pump again. The solvent is now circulating through the system and cleans the pipes to and from the spray head. After about 15 minutes rinsing the machine is drained. The solvent can be used four times total for a first-rinsing.

Place a container with a big enough capacity under the drain valve and the filter housing. Open the valve of the lacquer recipient and drain.

By means of the button „Reverse” on the touchscreen let the pump rotating backward in order to get as much solvent as possible out of the system. A second rinsing with clean solvent is made the same way as described. Use slightly contaminated solvent of second rinsing for the first rinsing.



Disposal of dirty solvent according to international and local regulations!

Filter cartidges

Depending on the processed lacquer system the cartidges have to changed from daily up to all two weeks.

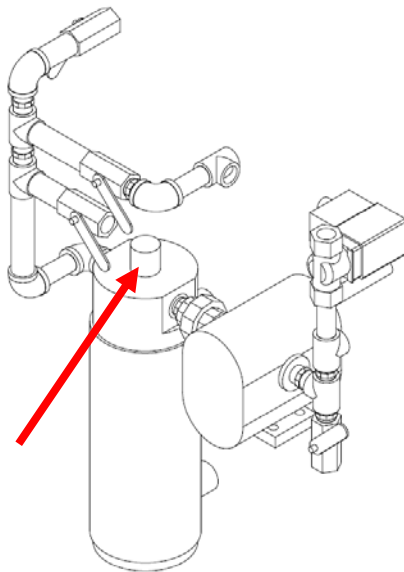

Dismounting the filter cartidge: Unscrew the screw and remove the filter housing to the bottom.



Filter cartidge 75µm