

BANCALE CON SCARICO 2"+GRIGLIE
INPUT CONVEYOR WITH DISCHARGED 2"
+ FLEX GUIDE

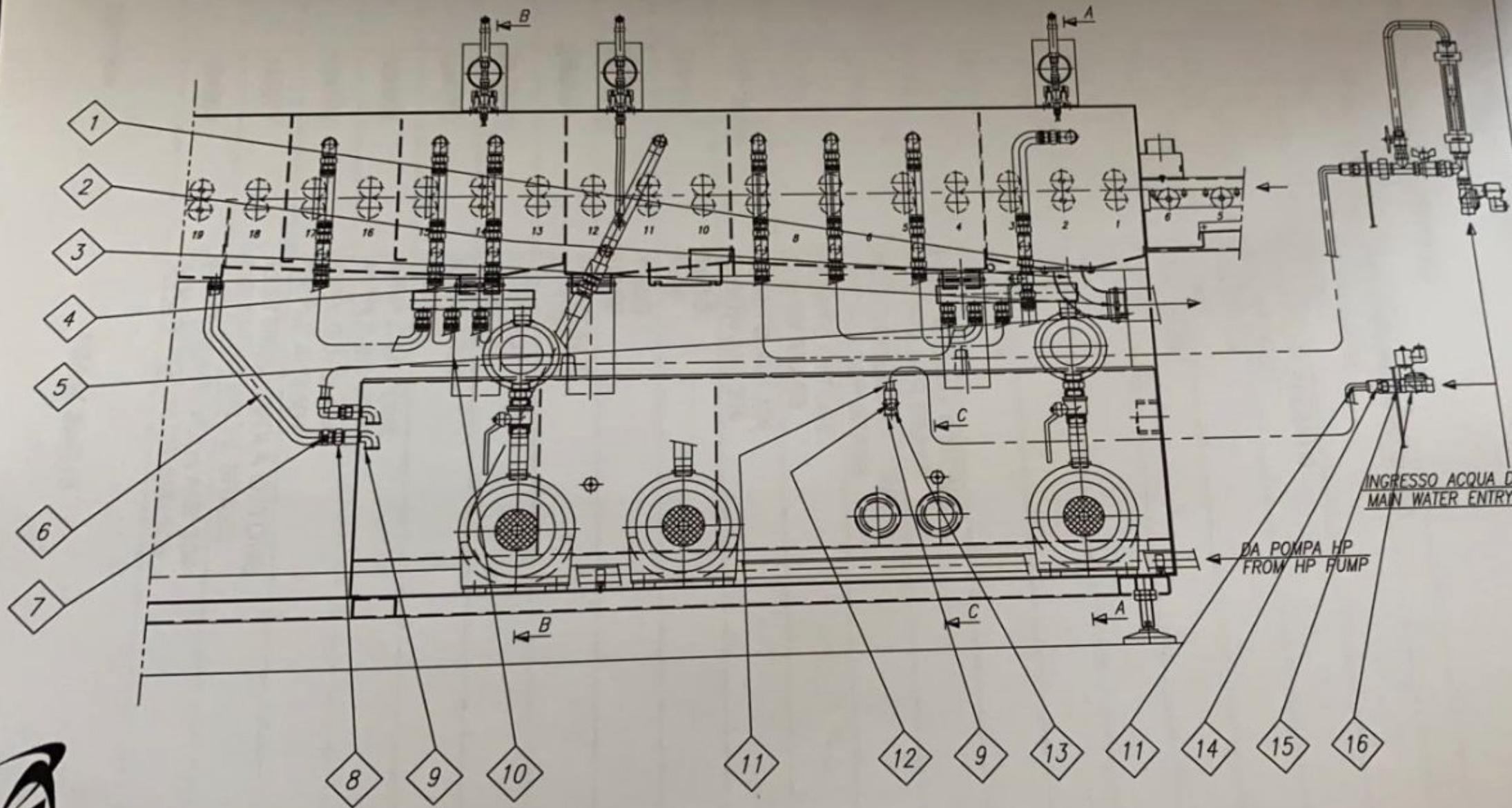

VERSIONE CON SCARICO 1^ CAMERA SEPARATO
VERSION WITH SEPARATE DISCHARGED 1^ CHAMBER

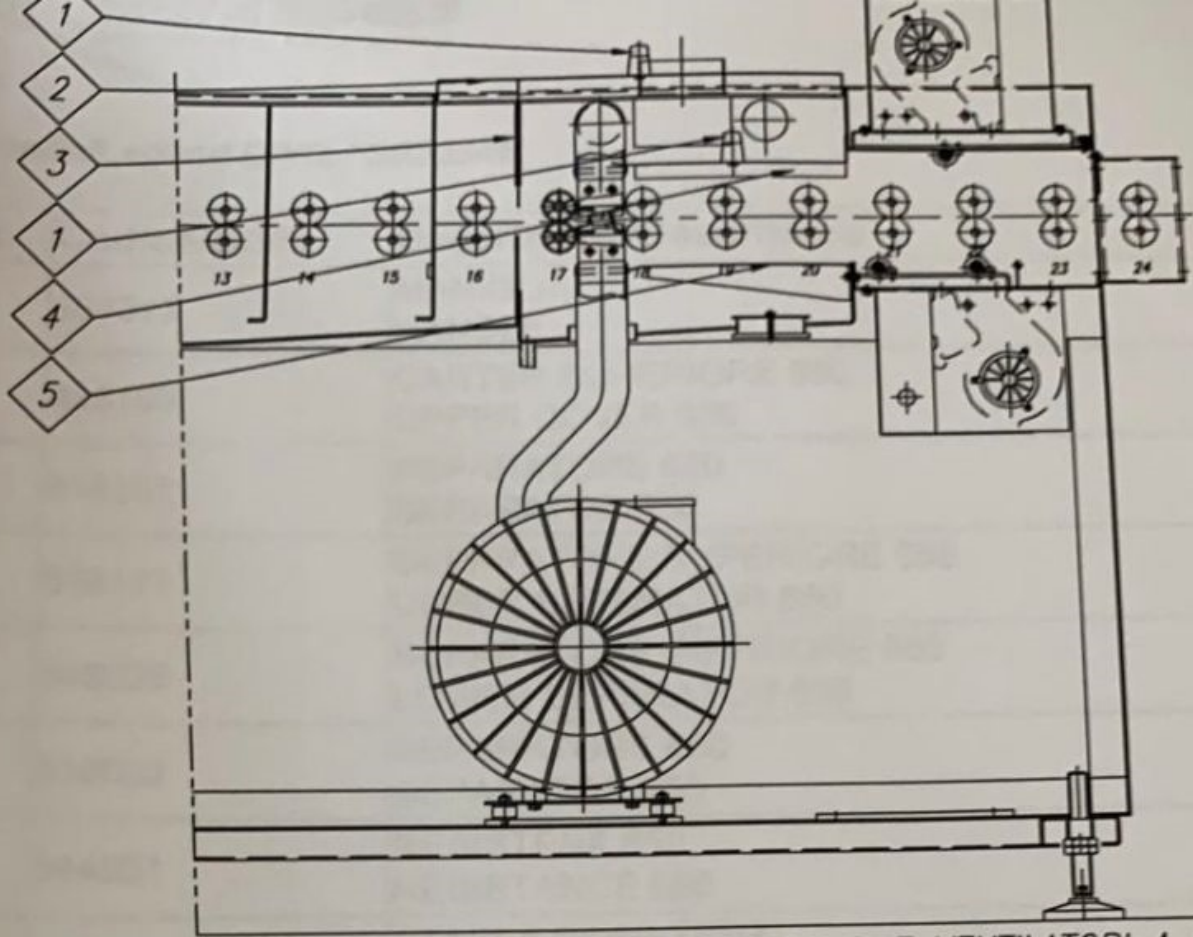



SIONE CON UNA COPPIA DI VENTILATORI E CON DUE VENTILATORI A GABBIA D
 SION WITH ONE COUPLE OF BLOWERS AND TWO SQUIRREL CAGE BLOWERS

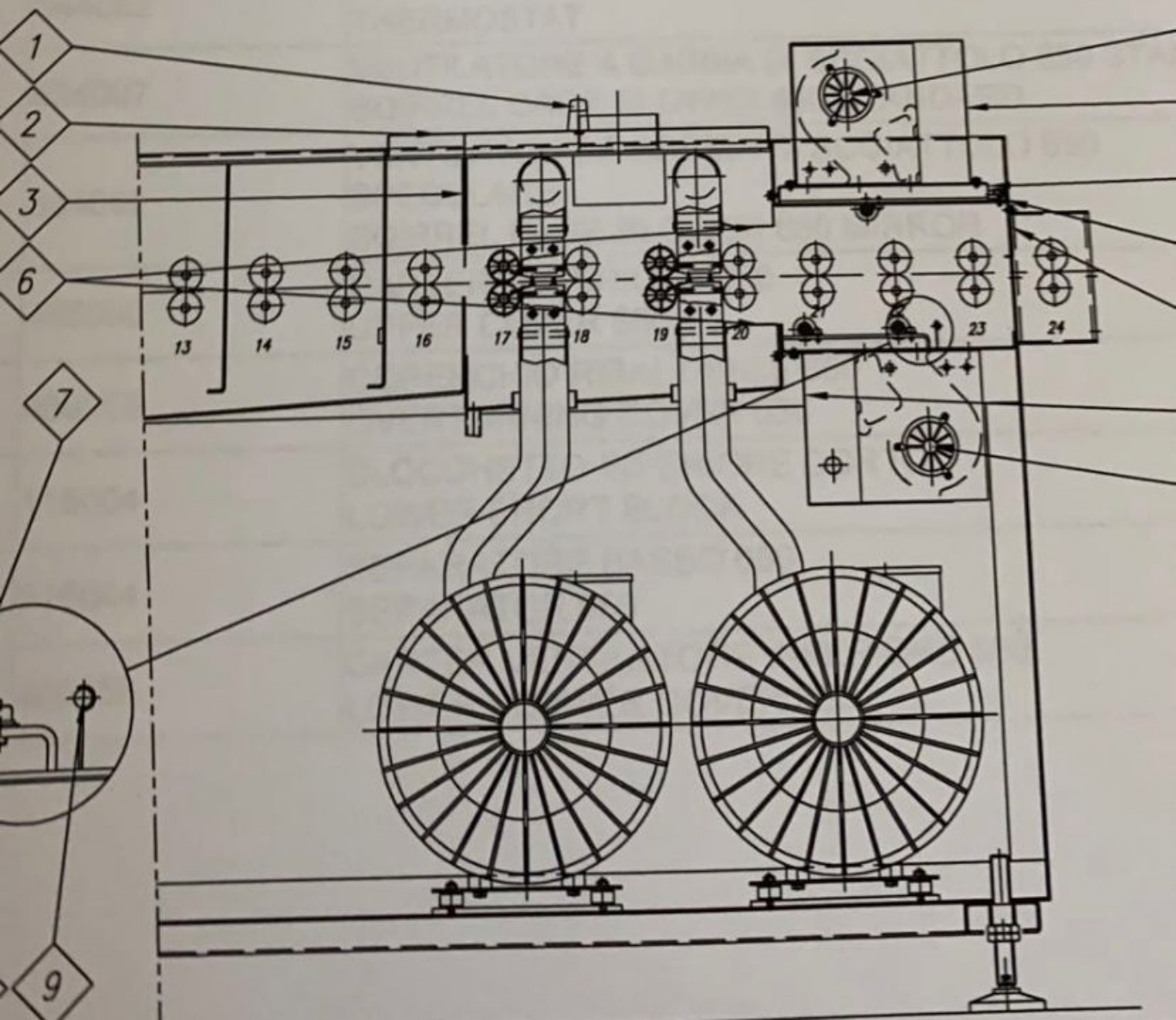

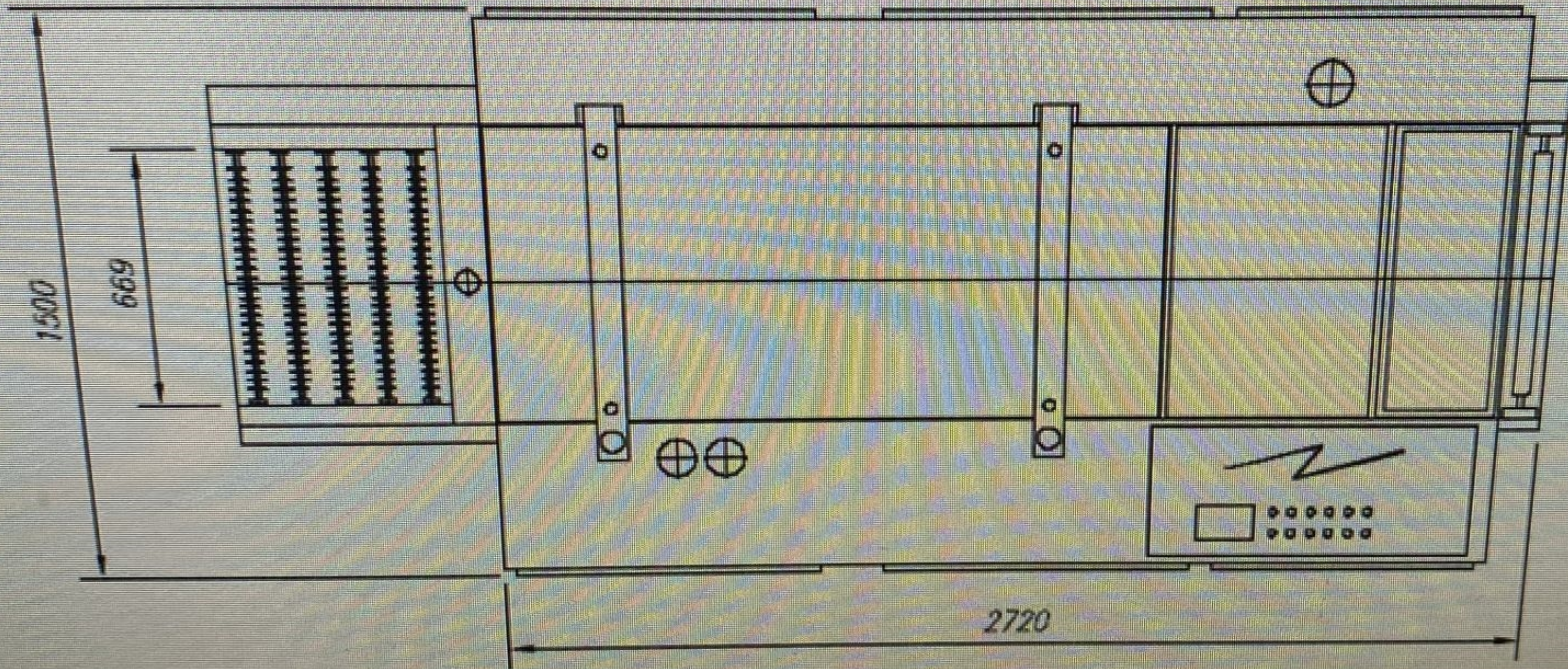
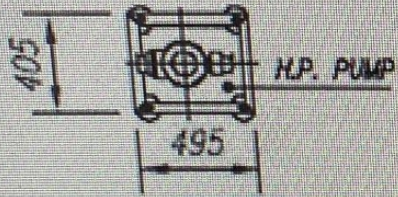

C. First washing chamber, 520mm length, equipped with:

- Centrifugal pump feeding the spraying pipes.
- Cartridge filter installed on the delivery side of the centrifugal pump.
- Two pairs of brushes.
- One heater controlled by thermostat, and dry operation protected by level switch.
- Compensation water comes in cascading from the tank of the subsequent chamber.
- Excess water evacuates by overflow.

D. Second washing chamber, 330mm length, equipped with:

- Centrifugal pump feeding the high pressure pump.
- Cartridge filter installed on the delivery side of the centrifugal pump.

FLUXSTAR 4 BRUSHES 650

