

Indice	Description de la modification	Date	Nom
1		09/06/2015	CDU

EXPLODED VIEW OF REGISTRATION

1 2 Clamping system to hold the panel during registration
3 4

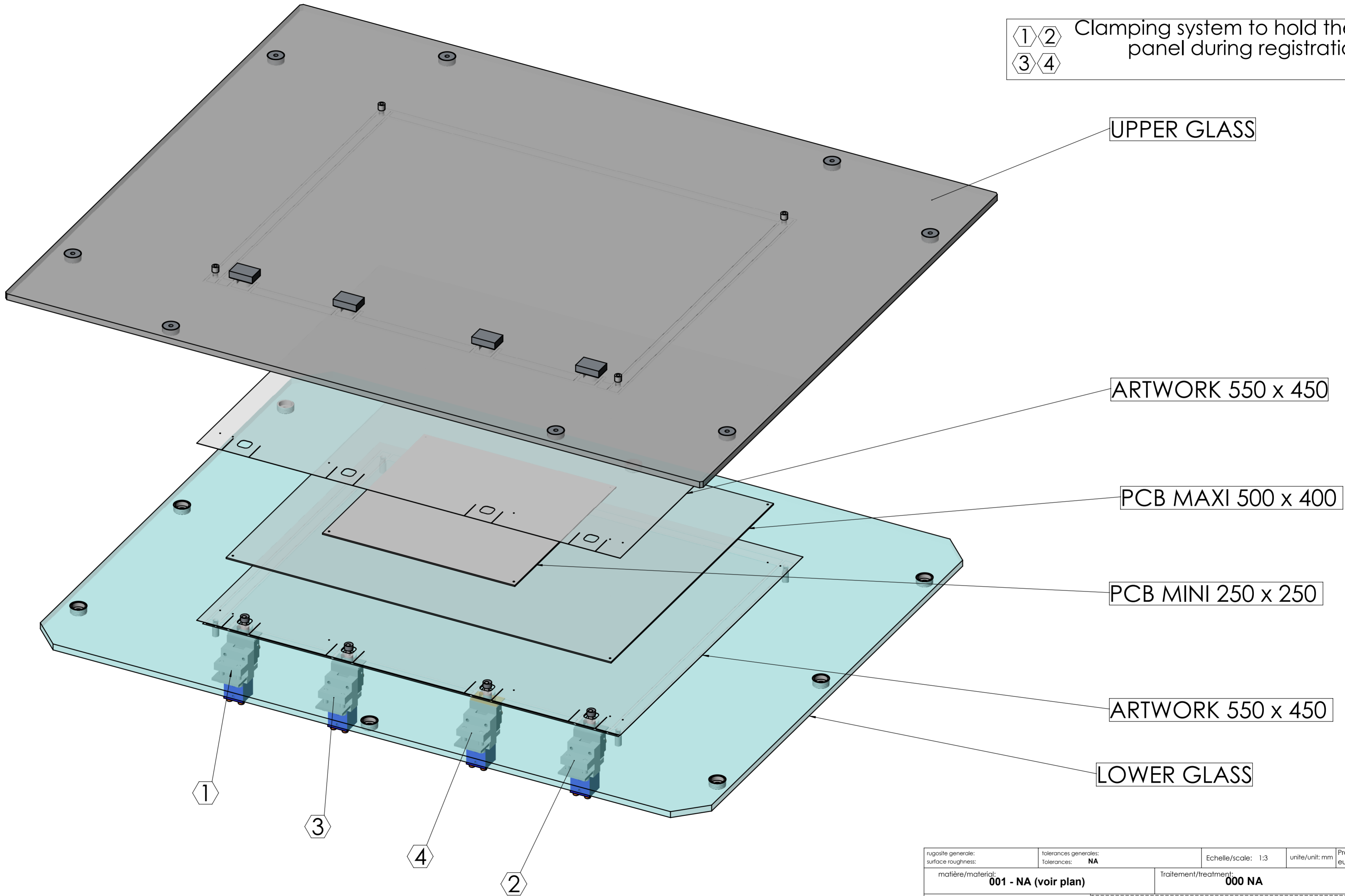

UPPER GLASS

ARTWORK 550 x 450

PCB MAXI 500 x 400

PCB MINI 250 x 250

ARTWORK 550 x 450

LOWER GLASS

rugosité générale: surface roughness:	tolérances générales: Tolerances: NA	Echelle/scale: 1:3	unité/unit: mm	Projection européenne
matière/material: 001 - NA (voir plan)		Traitement/treatment: 000 NA		
XXX	COTE MAJEURE A CONTROLER A LA RECEPTION	désignation REGISTRATION AA052 500x400 KINGTECH	numero/number: COM1135	Indice plan 01
 Tel : 02.32.63.36.36 Fax : 02.32.63.36.37		Feuille/leaf: 1 / 7	Format A2	
Tous droits strictement réservés. Reproduction ou communication à des tiers interdite sans autorisation écrite du propriétaire. All rights strictly reserved. Copyright or communication to a third party is not permitted without written authorization of the owner.		Nom/Name: CC	Date: 09/06/15	cartouche du 04/11/2013 indice plan :
Poids/weight:		D.A.O: Solidworks		

Lower glass

ARTWORK 450 x 550

Vacuum grooves

PCB MAXI 500 x 400

PCB MINI 250 x 250

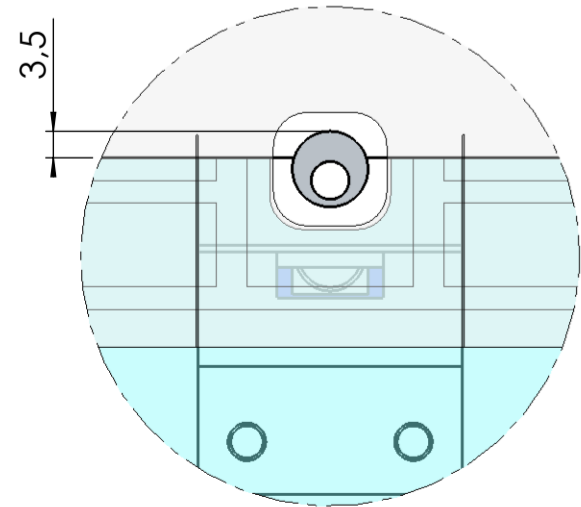
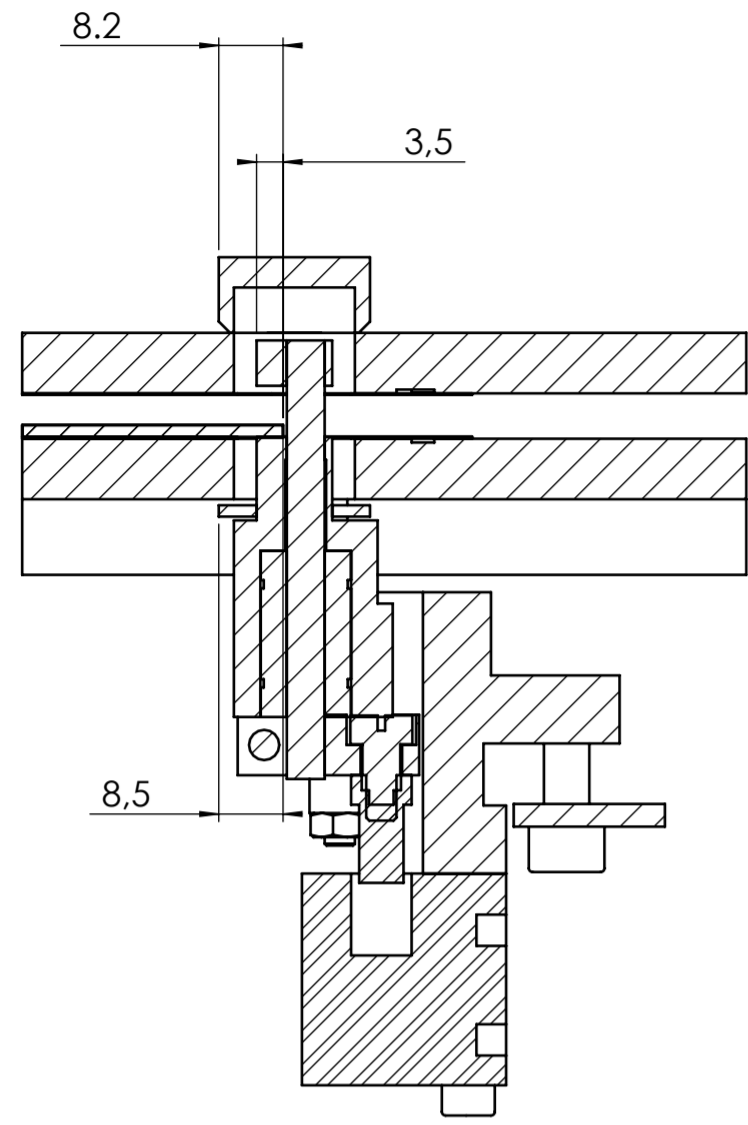

DÉTAIL A
ECHELLE 1 : 1

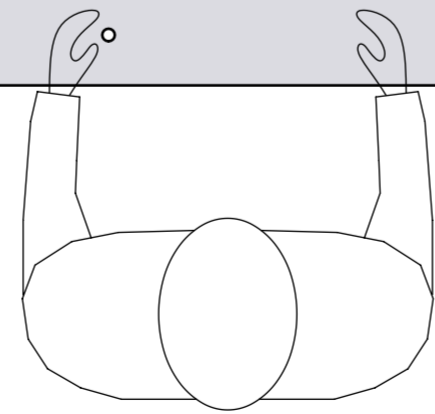
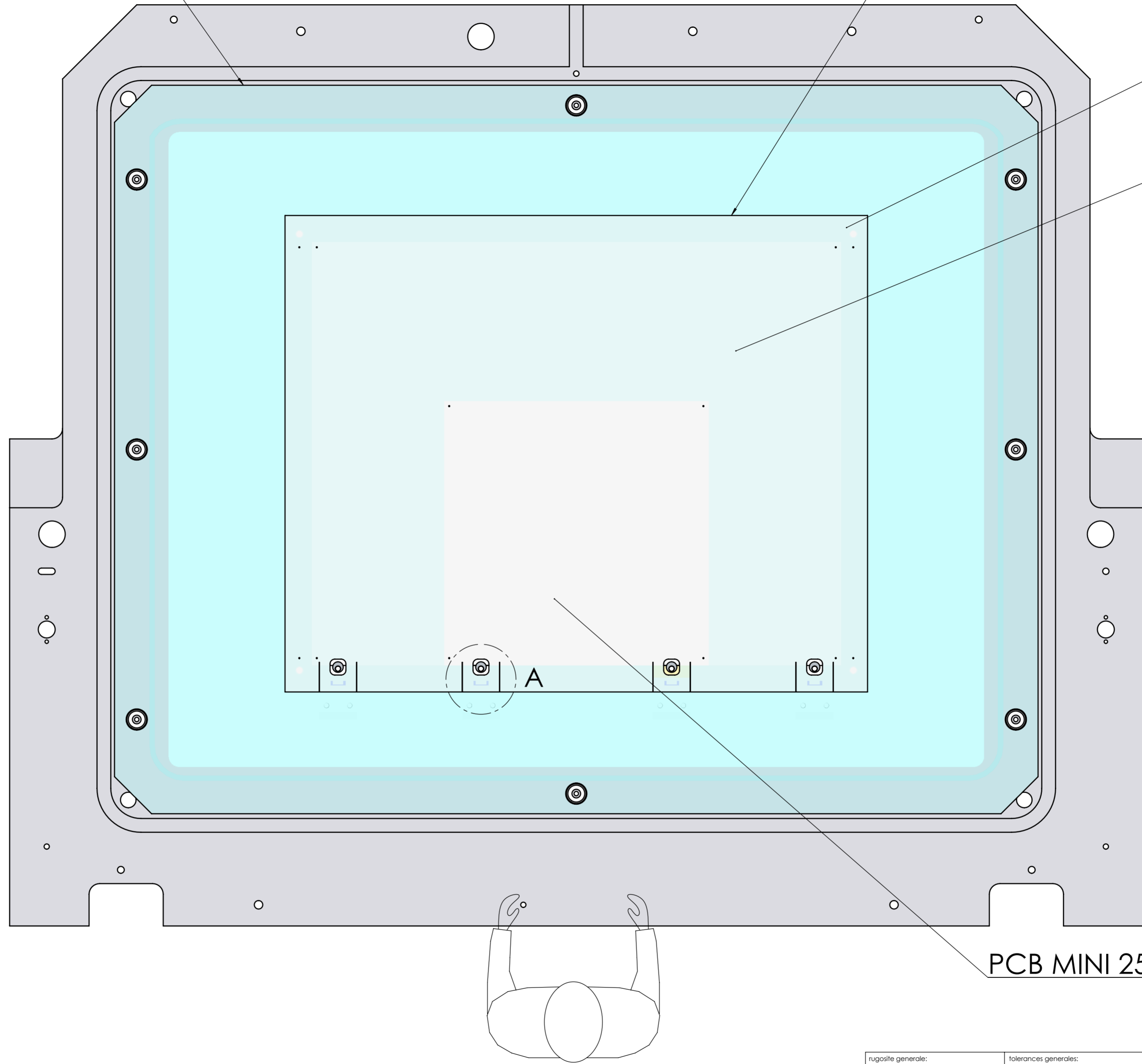

rugosité generale: surface roughness:	tolerances generales: Tolerances: NA	Echelle/scale: 1:3	unite/unit: mm	Projection européenne
matière/material: 001 - NA (voir plan)		Traitement/treatment: 000 NA		
XXX COTE MAJEURE A CONTROLER A LA RECEPTION 		désignation REGISTRATION AA052 500x400 KINGTECH	numero/number: COM1135	Indice plan 01
Tel : 02.32.63.36.36 Fax : 02.32.63.36.37		Feuille/leaf: 2 / 7		Format A2
Nom/Name: CC		Date: 09/06/15	cartouche du 04/11/2013	
Tous droits strictement réservés. Reproduction ou communication à des tiers interdite sans autorisation écrite du propriétaire. All rights strictly reserved. Copyright or communication to a third party is not permitted without written authorization of the owner.		Poids/weight:	D.A.O.: Solidworks	indice plan :

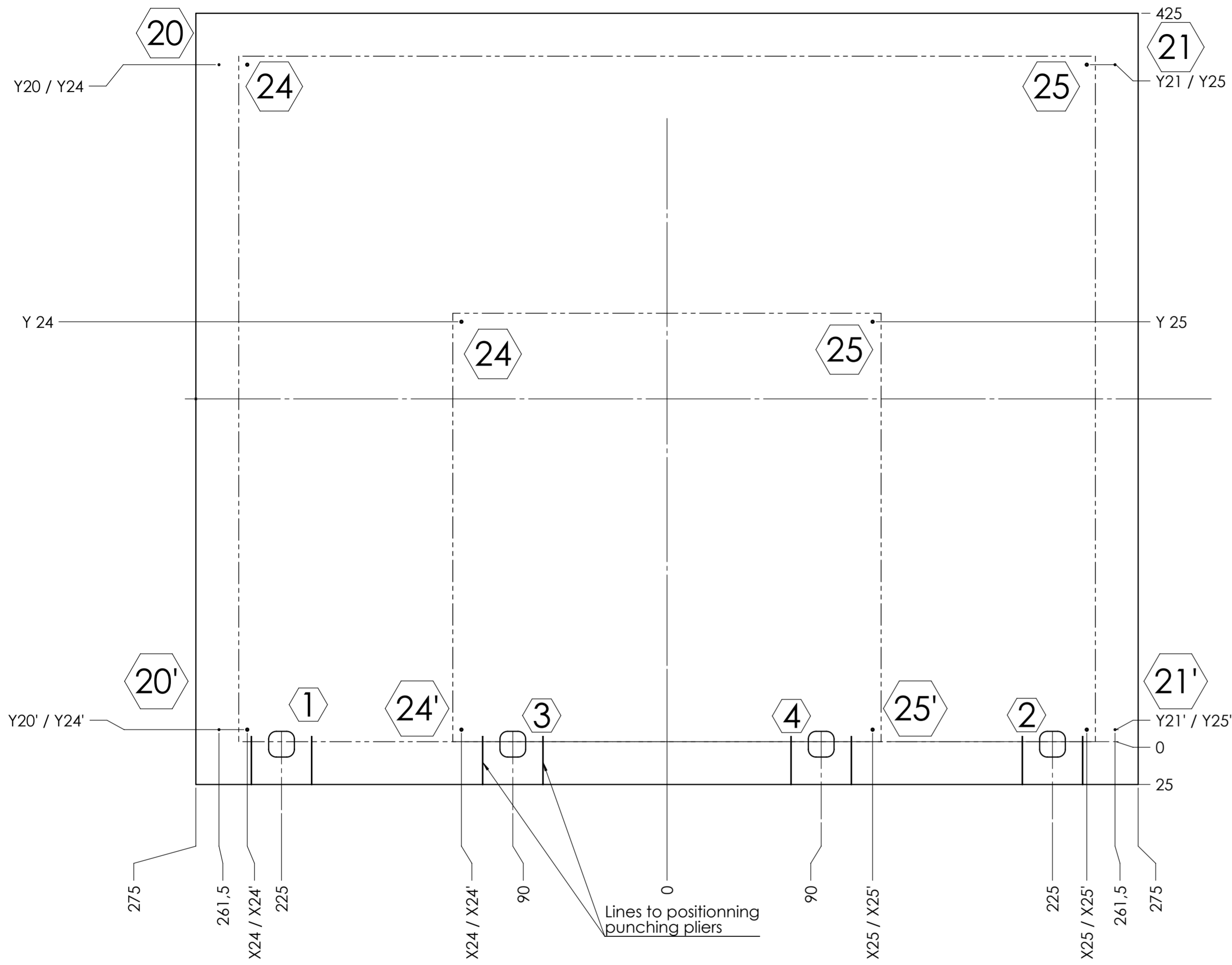

- 1
2 Clamping system.
 - 3
4 - See detail 1

- 20
21 Targets for the Inner Layers registration.
 - 20'
21' - See detail 3

- 24
25 Targets and holes for outer layers registration
 - 24'
25' - See detail 2
 - The accessible positions to locate the targets are determined on page 7/7

Detail of the artworks

This is a view from top of the artworks when it is in exposure unit for the lower artworks, emulsion is above for the upper artworks, emulsion is under

Remark: size accuracy of the artworks: +/-0.5mm

rugosité générale: surface roughness:	tolérances générales: Tolerances: NA	Echelle/scale: 1:3	unité/unit: mm	Projection européenne
matière/material: 001 - NA (voir plan)		Traitement/treatment: 000 NA		
XXX	COTE MAJEURE A CONTROLER A LA RECEPTION	désignation REGISTRATION AA052 500x400 KINGTECH	numero/number: COM1135	Indice plan 01
ALTIX AUTOMATION TECHNOLOGIES Tel : 02.32.63.36.36 Fax : 02.32.63.36.37		Nom/Name: CC	Date: 09/06/15	Format A2
Tous droits strictement réservés. Reproduction ou communication à des tiers interdite sans autorisation écrite du propriétaire. All rights strictly reserved. Copyright or communication to a third party is not permitted without written authorization of the owner.		Poids/weight:	D.A.O: Solidworks	cartouche du 04/11/2013 indice plan :

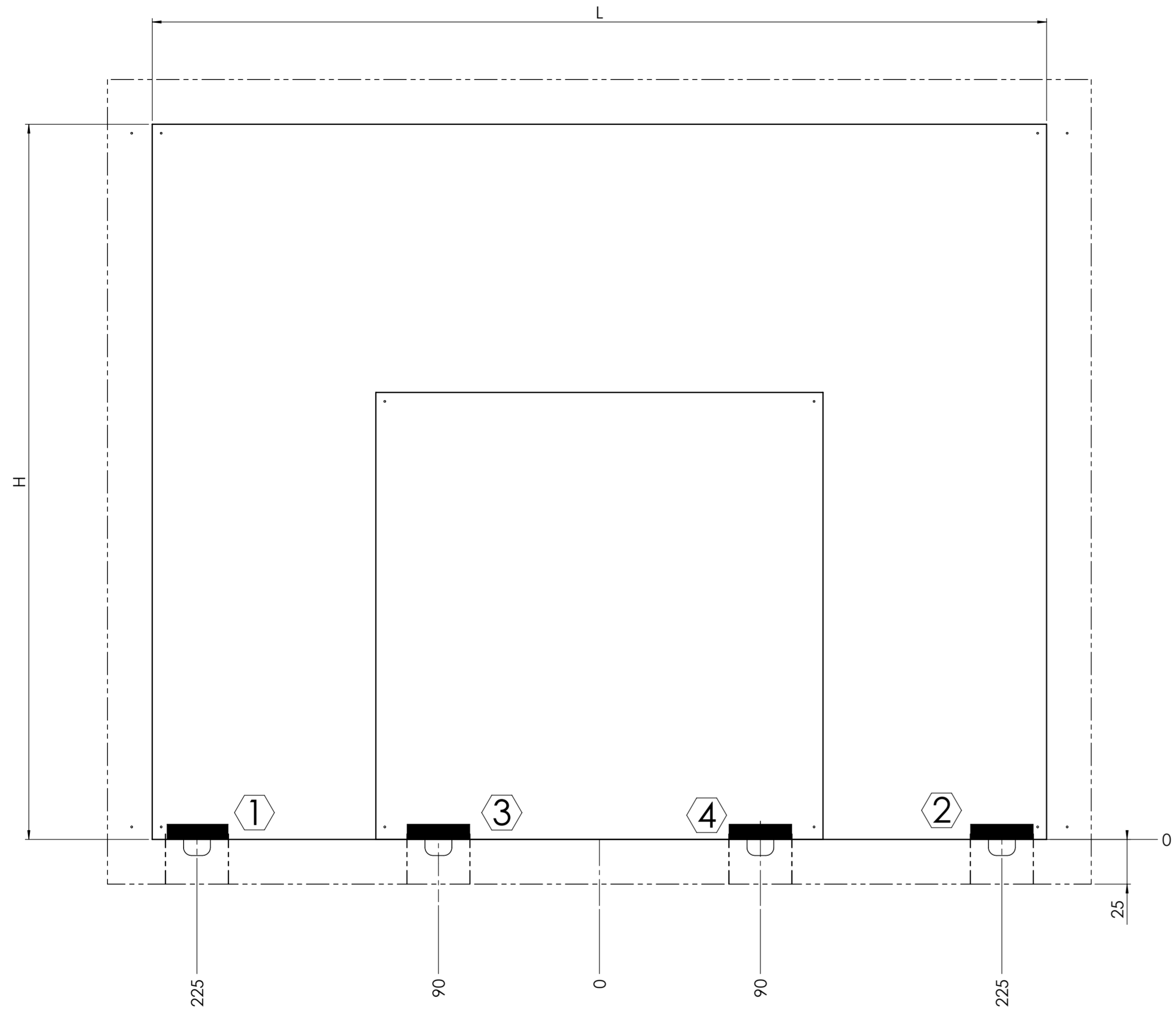

① ② Shadows
 ③ ④ - See detail C

detail of the PCB
 (Inner layers)

rugosité générale: surface roughness:	tolérances générales: Tolerances: NA	Echelle/scale: 1:3	unité/unit: mm	Projection européenne
matière/matériau: 001 - NA (voir plan)		traitement/traitement: 000 NA		
XXX COTE MAJEURE A CONTROLER A LA RECEPTION	désignation REGISTRATION AA052 500x400 KINGTECH	numero/number: COM1135	Indice plan 01	
ALTIX AUTOMATION TECHNOLOGIES Tel : 02.32.63.36.36 Fax : 02.32.63.36.37	Nom/Name: CC	Date: 09/06/15	Format A2	
Tous droits strictement réservés. Reproduction ou communication à des tiers interdite sans autorisation écrite du propriétaire. All rights strictly reserved. Copyright or communication to a third party is not permitted without written authorization of the owner.		Poids/weight:	D.A.O: Solidworks	cartouche du 04/11/2013 indice plan :

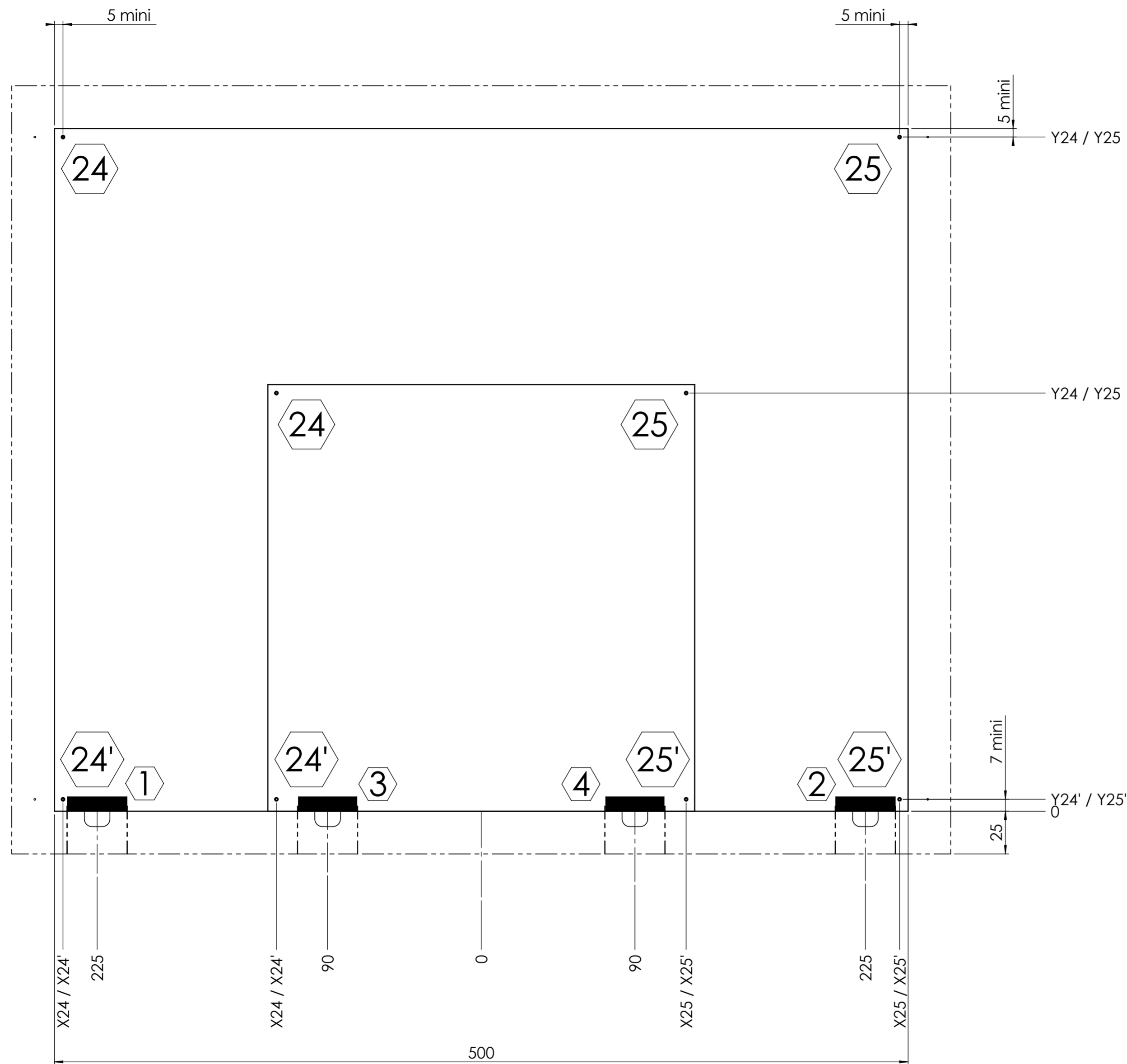

1 2 Shadows
3 4 - See detail C

24 25 Holes for outer
24' 25' layers registration
 - See detail B

detail of the PCB
(outer layers)

rugosité générale: surface roughness:	tolérances générales: Tolerances: NA	Echelle/scale: 1:3	unité/unit: mm	Projection européenne
matière/matériau: 001 - NA (voir plan)		traitement/traitement: 000 NA		
XXX COTE MAJEURE A CONTROLER A LA RECEPTION	désignation REGISTRATION AA052 500x400 KINGTECH	numero/number: COM1135	Indice plan 01	
ALTIX AUTOMATION TECHNOLOGIES Tel : 02.32.63.36.36 Fax : 02.32.63.36.37	Nom/Name: CC	Date: 09/06/15	Format A2	
Tous droits strictement réservés. Reproduction ou communication à des tiers interdite sans autorisation écrite du propriétaire. All rights strictly reserved. Copyright or communication to a third party is not permitted without written authorization of the owner.		Poids/weight:	D.A.O: Solidworks	cartouche du 04/11/2013 indice plan :

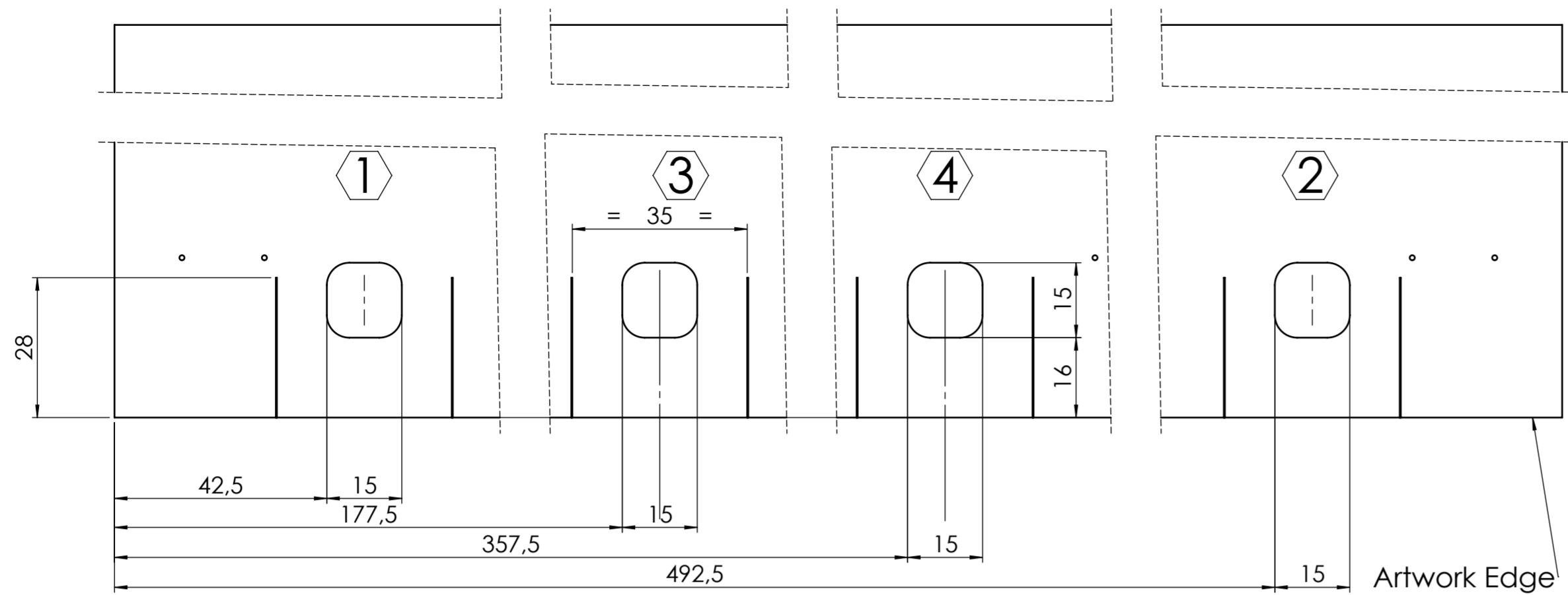

- Detail 1
Holes made
by punching pliers

Details of the
the artworks

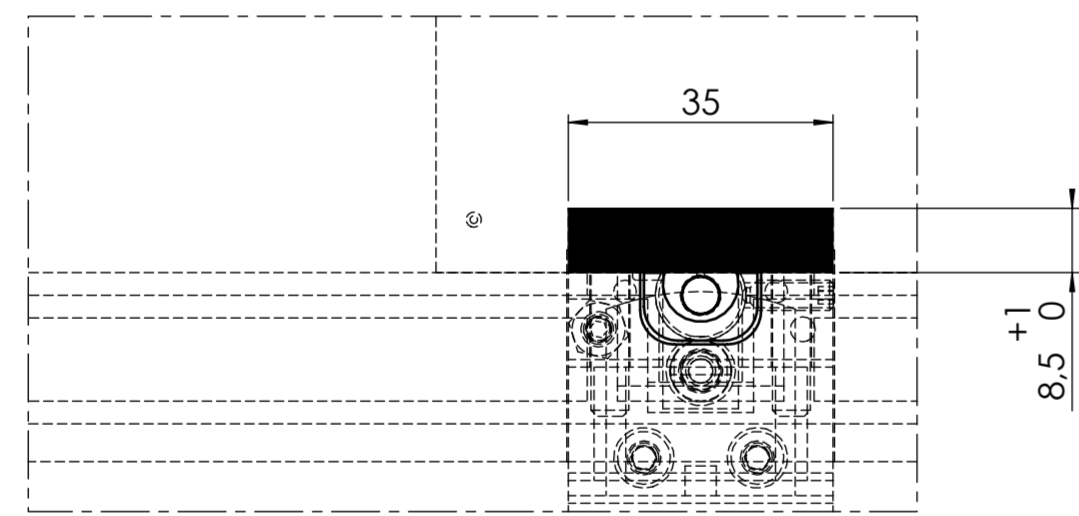
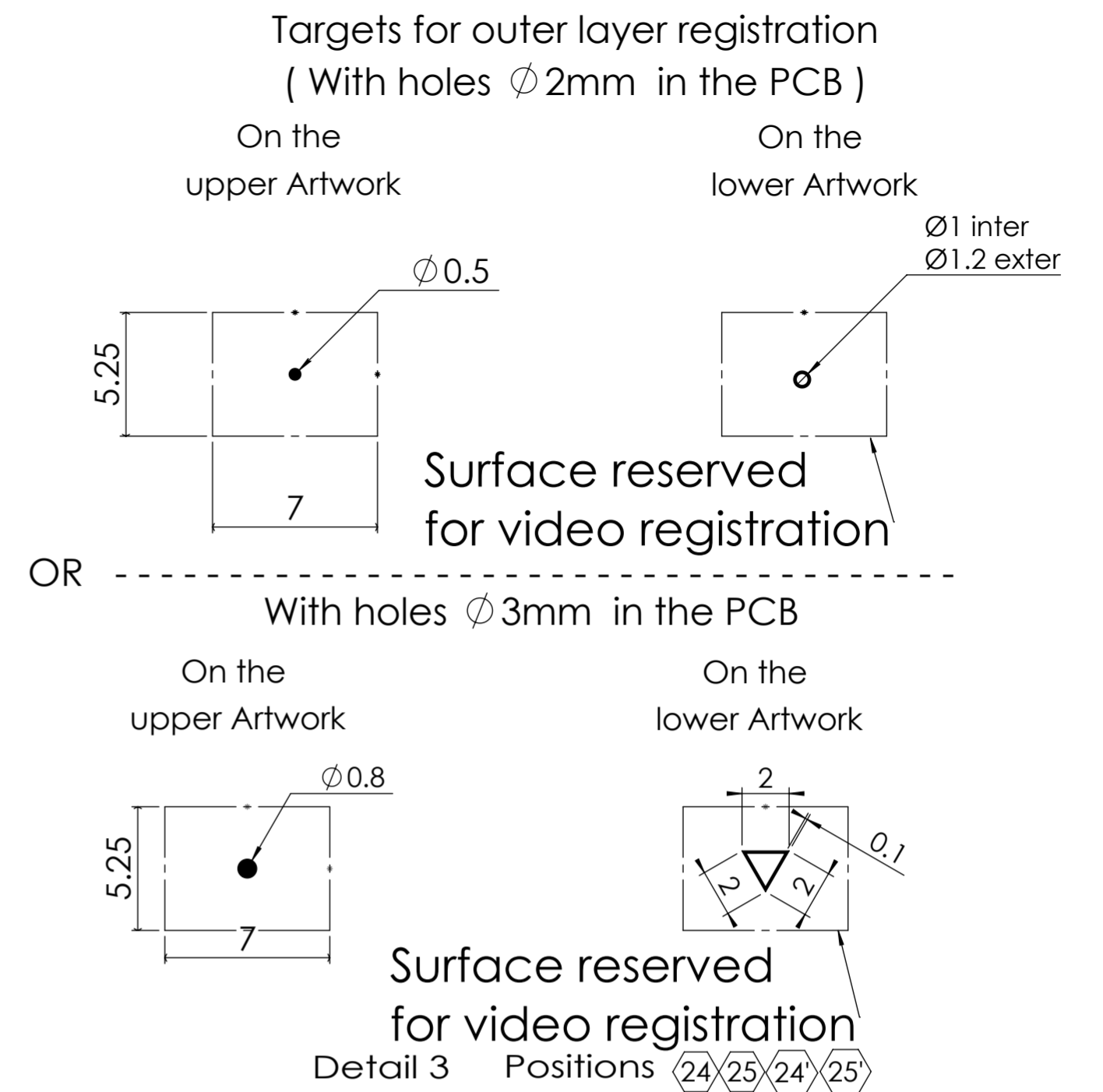

DÉTAIL C
ECHELLE 1 : 1

Positions $\langle 1 \rangle \langle 2 \rangle$
 $\langle 3 \rangle \langle 4 \rangle$

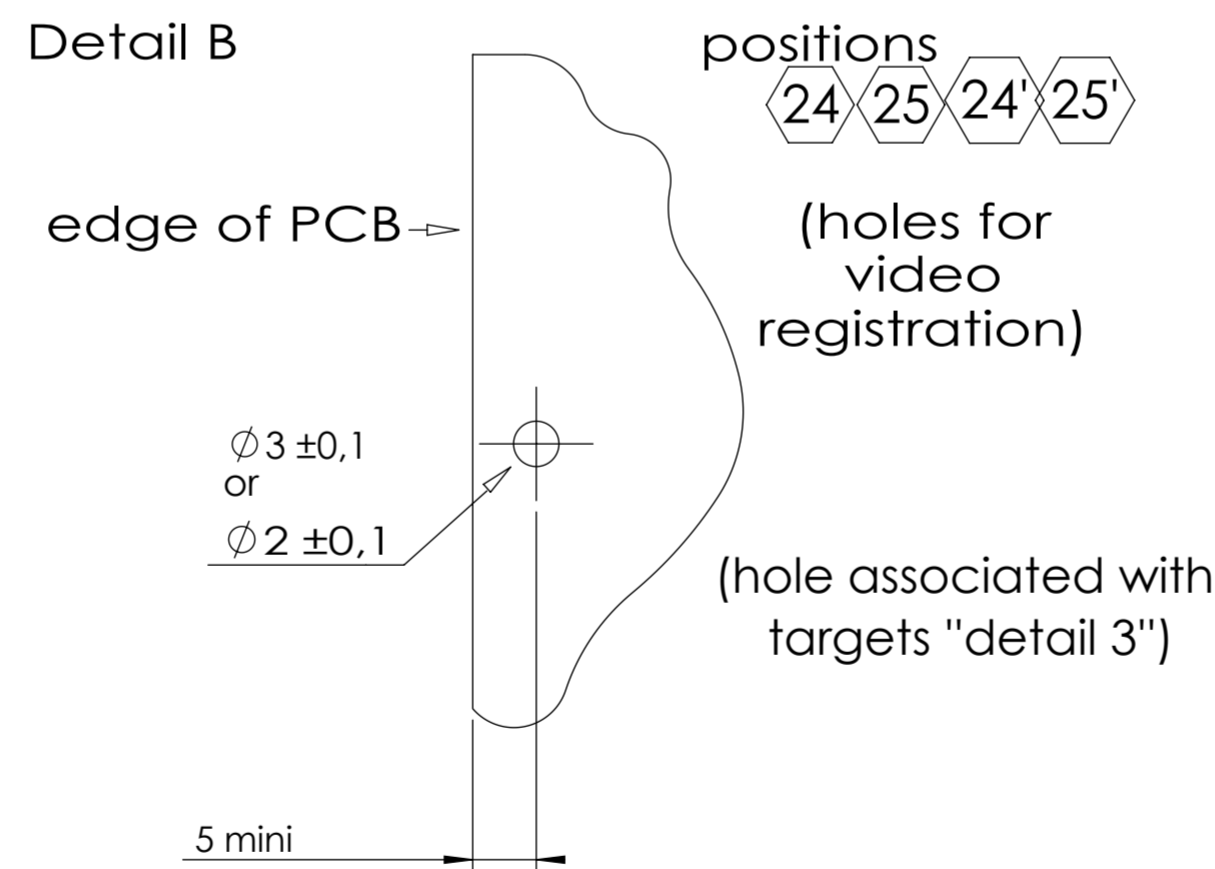

Details of the
the PCB

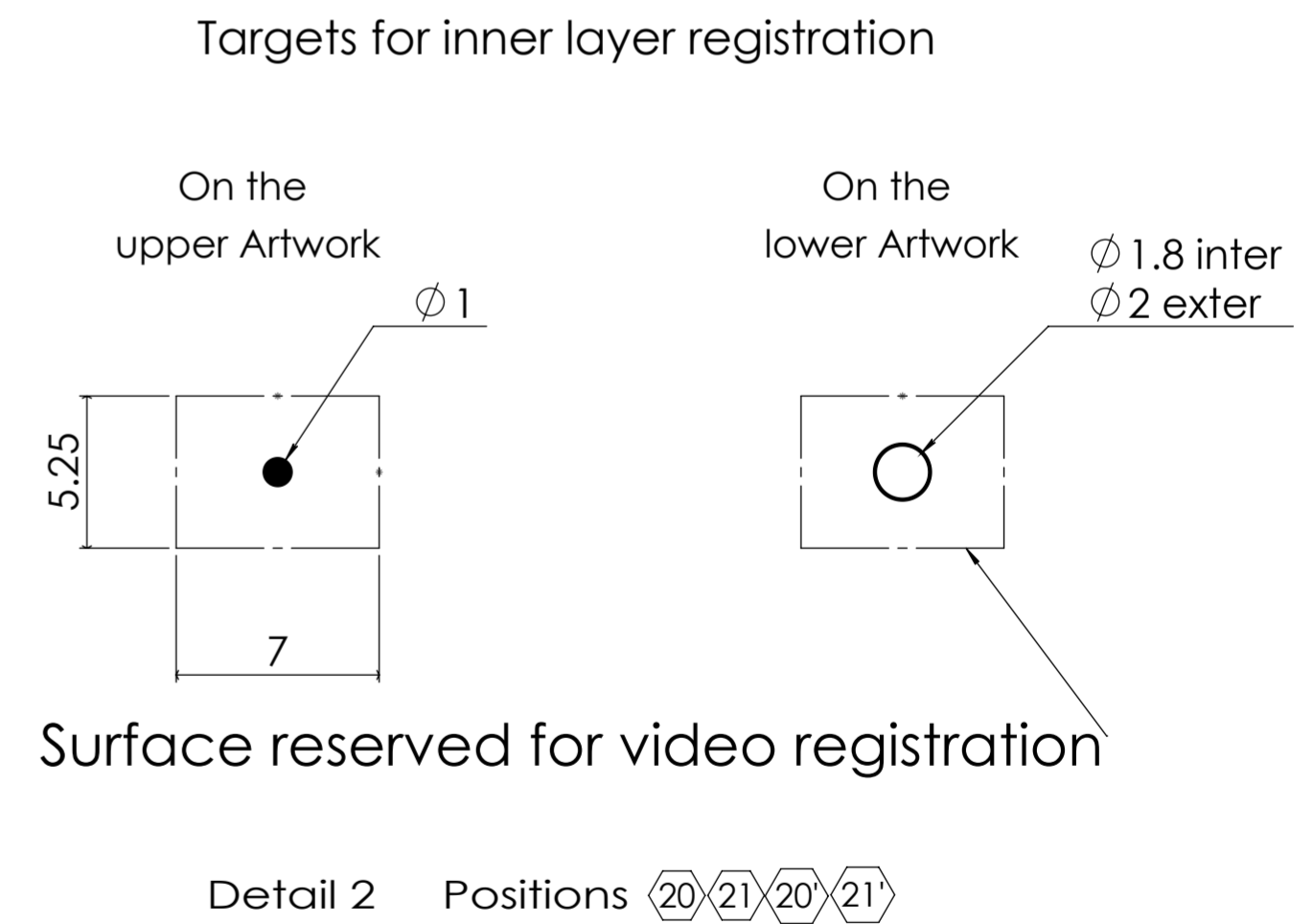

rugosité générale: surface roughness:	tolérances générales: Tolerances: NA	Echelle/scale: 1:3	unité/unit: mm	Projection européenne
matière/material: 001 - NA (voir plan)		Traitement/treatment: 000 NA		
XXX COTE MAJEURE A CONTROLER A LA RECEPTION	désignation REGISTRATION AA052 500x400 KINGTECH	numero/number: COM1135	Indice plan 01	
ALTIX AUTOMATION TECHNOLOGIES Tel : 02.32.63.36.36 Fax : 02.32.63.36.37	Nom/Name: CC	Feuille/leaf: 6 / 7	Date: 09/06/15	Format A2
Tous droits strictement réservés. Reproduction ou communication à des tiers interdite sans autorisation écrite du propriétaire. All rights strictly reserved. Copyright or communication to a third party is not permitted without written authorization of the owner.		Poids/weight:	D.A.O: Solidworks	cartouche du 04/11/2013 indice plan :

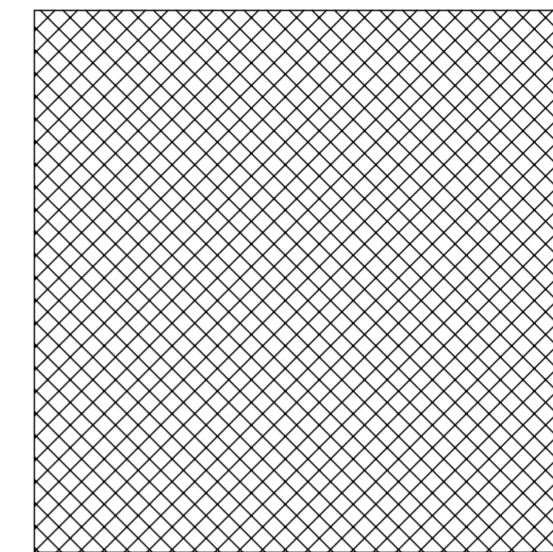
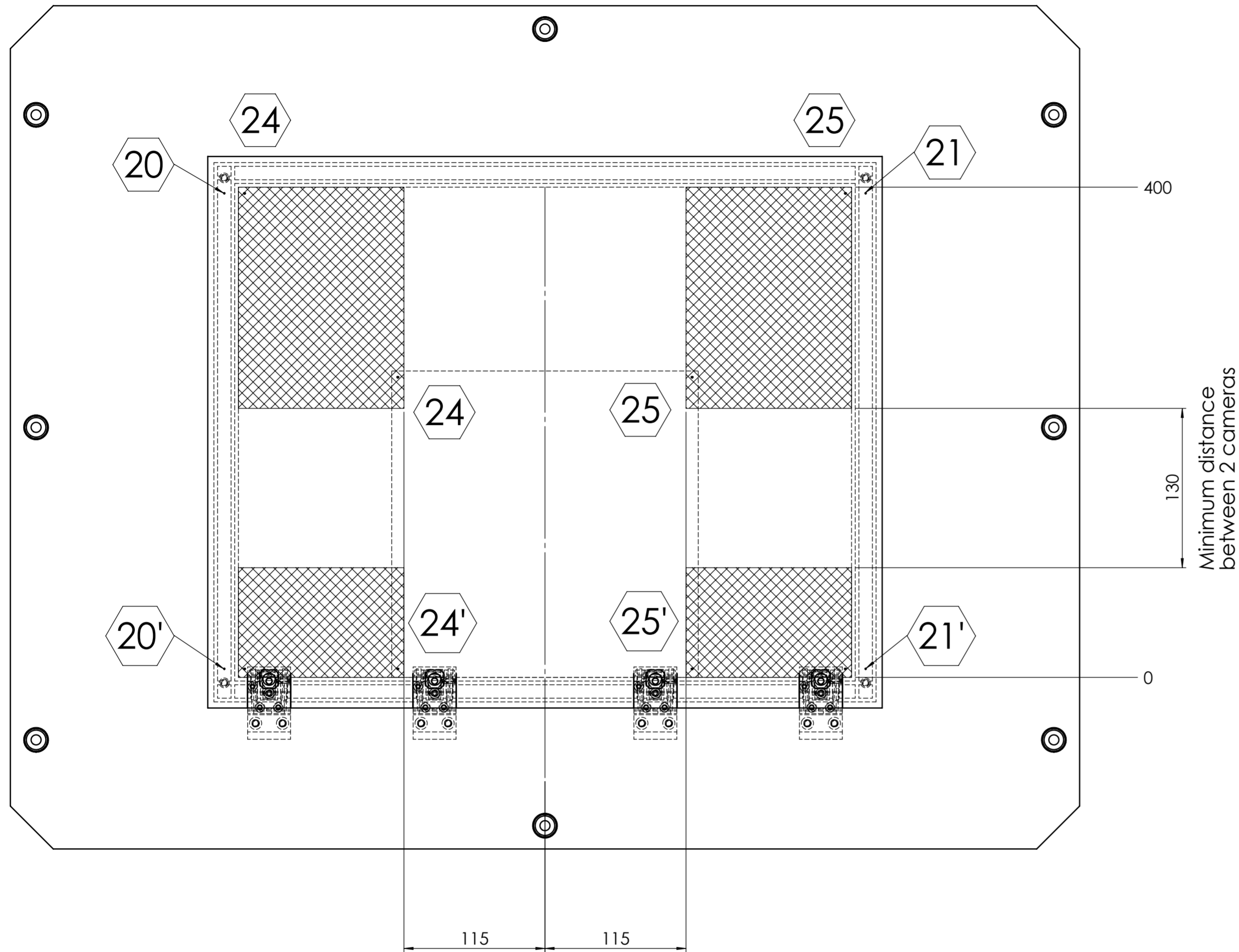

Area where the targets can be plotted for Outer layer registration

Cameras area for the video registration

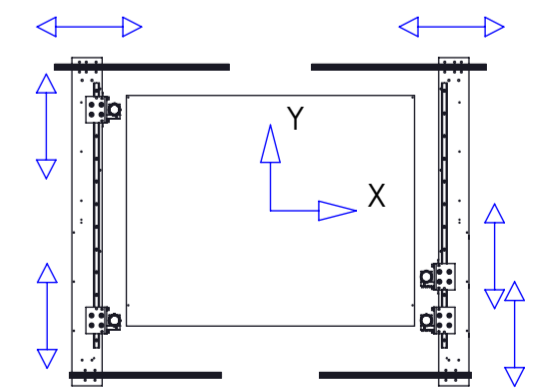

Registration with 4 cameras

rugosité générale: surface roughness:	tolérances générales: Tolerances: NA	Echelle/scale: 1:3	unité/unit: mm	Projection européenne
matière/matériau: 001 - NA (voir plan)		traitement/traitement: 000 NA		
XXX	COTE MAJEURE A CONTROLER A LA RECEPTION	désignation REGISTRATION AA052 500x400 KINGTECH	numero/number: COM1135	indice plan 01
		Nom/Name: CC	Feuille/leaf: 7 / 7	Format A2
Tous droits strictement réservés. Reproduction ou communication à des tiers interdite sans autorisation écrite du propriétaire. All rights strictly reserved. Copyright or communication to a third party is not permitted without written authorization of the owner.		Poids/weight:	D.A.O: Solidworks	cartouche du 04/11/2013 indice plan :